

INSTRUCTION MANUAL

TYPE
RM
503
OSCILLOSCOPE



MANUFACTURERS OF CATHODE-RAY OSCILLOSCOPES

INSTRUCTION MANUAL

Serial No. 6901

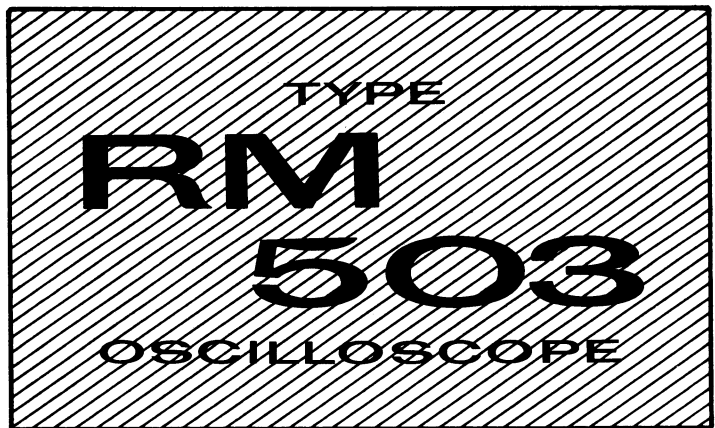

Tektronix, Inc.

S.W. Millikan Way • P. O. Box 500 • Beaverton, Oregon 97005 • Phone 644-0161 • Cables: Tektronix



WARRANTY

All Tektronix instruments are warranted against defective materials and workmanship for one year. Tektronix transformers, manufactured in our own plant, are warranted for the life of the instrument.

Any questions with respect to the warranty mentioned above should be taken up with your Tektronix Field Engineer.

Tektronix repair and replacement-part service is geared directly to the field, therefore all requests for repairs and replacement parts should be directed to the Tektronix Field Office or Representative in your area. This procedure will assure you the fastest possible service. Please include the instrument Type and Serial number with all requests for parts or service.

Specifications and price change privileges reserved.

Copyright © 1963 by Tektronix, Inc., Beaverton, Oregon. Printed in the United States of America. All rights reserved. Contents of this publication may not be reproduced in any form without permission of the copyright owner.



CONTENTS

- Section 1 Characteristics**
- Section 2 Preliminary Information**
- Section 3 Operating Instructions**
- Section 4 Circuit Description**
- Section 5 Maintenance**
- Section 6 Calibration**
- Section 7 Parts List & Schematics**

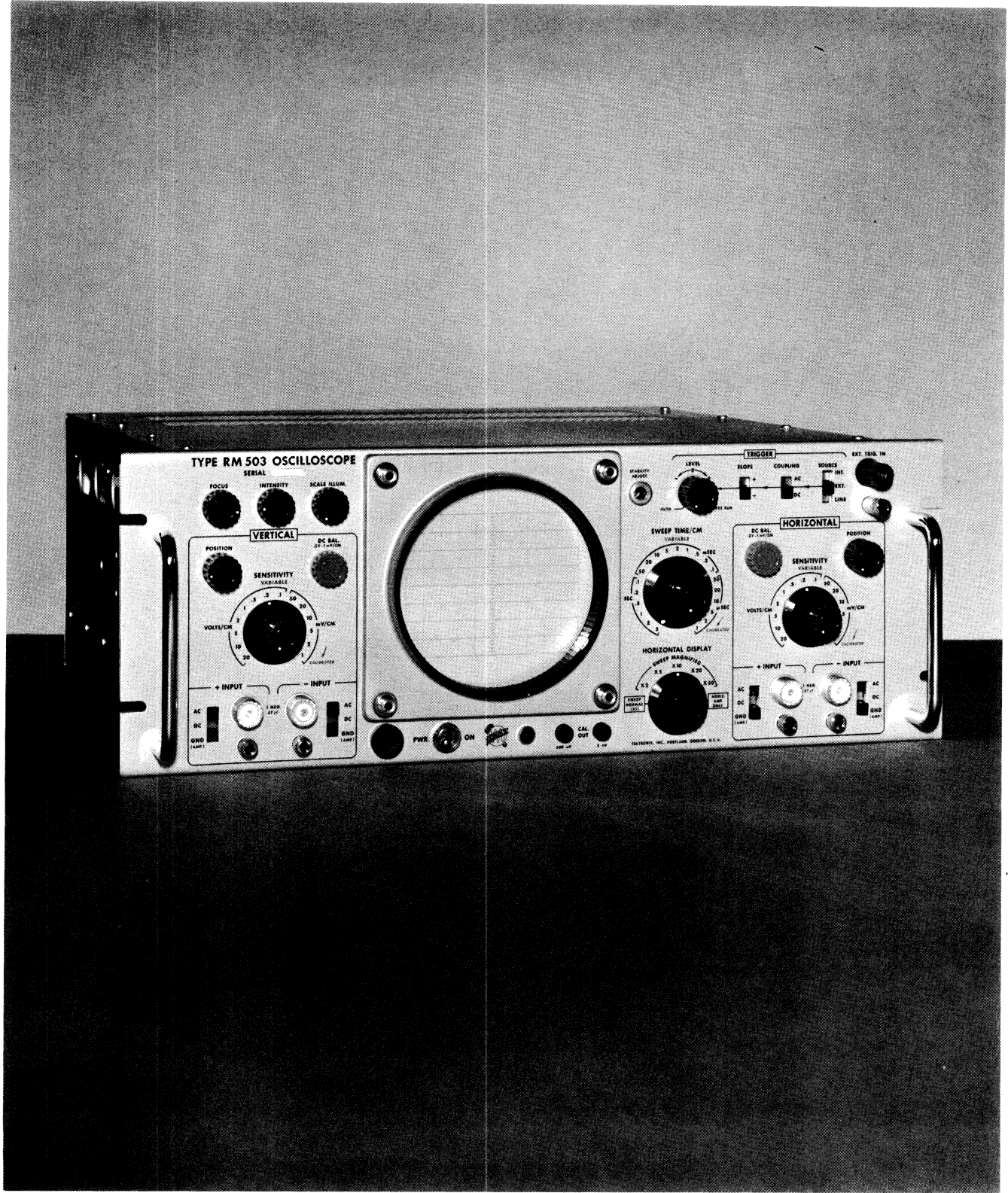

Type RM503

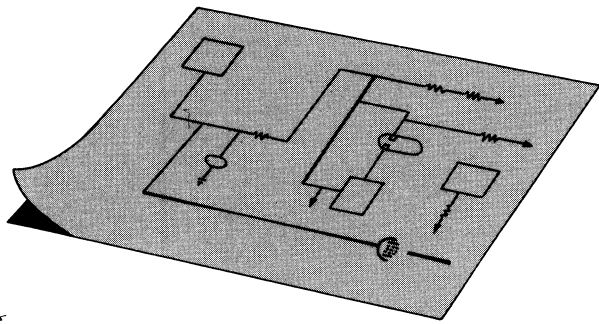

SECTION 1

CHARACTERISTICS

Introduction

The Tektronix Type RM503 Oscilloscope is a low-frequency, high-sensitivity laboratory instrument providing accurate measurements in the range from dc to 450 kc. Identical vertical and horizontal amplifiers may be used for accurate curve plotting in the X-Y mode of operation. Both amplifiers may be operated with single-ended inputs for conventional operation, or with differential inputs for cancellation of common-mode signals. Sweep rates to 1 microsecond per centimeter, combined with sweep magnification factors to 50, provide effective calibrated sweep rates to 0.1 microsecond per centimeter.

Vertical and Horizontal Deflection System

Input Impedance—1 megohm paralleled by 47 μf .

Coupling—AC or DC.

Deflection Factors—Fourteen calibrated deflection factors from 1 millivolt to 20 volts per centimeter, accurate within 3%.

Bandpass—DC to ≤ -3 dB at 450 kc.

Differential Input Rejection Ratio—100 to 1 from 1 millivolt to 0.2 volt per centimeter sensitivity; 50 to 1 from 0.5 volt to 20 volts per centimeter sensitivity. The rejection ratios specified apply if the signal voltages at the INPUT connectors do not exceed the following limits: ± 2 volts dc, or 4 volts peak-to-peak ac, at sensitivities of 1 millivolt to 0.2 volt per centimeter; ± 20 volts dc, or 40 volts peak-to-peak ac, at sensitivities of 0.5 volt to 2 volts per centimeter; ± 200 volts dc, or 400 volts peak-to-peak ac, at sensitivities of 5 volts per centimeter.

Triggering

Type—Automatic, or amplitude-level selection using pre-set stability.

Coupling—AC or DC.

Slope—Plus, from rising slope of triggering waveform, or minus, from negative slope of triggering waveform.

Signal Requirements—Internal: signal producing 0.5 cm vertical deflection. External: 0.5 volt to 10 volts of either polarity.

Sweep

Type—Miller Integrator.

Rates—Twenty-one calibrated sweep rates from 1 microsecond to 5 seconds per centimeter. Accuracy typically within 1% of the indicated sweep rate; in all cases within 3%.

Magnifier—Displayed waveforms can be expanded horizontally by a factor of 2, 5, 10, 20, or 50. Calibration of magnified sweep rates accurate within 5% of sweep rates which do not exceed the maximum calibrated rate of 0.1 microsecond per centimeter.

Amplitude Calibrator

Waveform—Square waves at approximately 350 cps.

Amplitude—5 millivolts and 500 millivolts peak-to-peak.

Cathode-Ray Tube

Type—T503P.

Phosphor—Type P2 normally furnished; P1, P7, P11, and P31 phosphors optional. Other phosphors available on special order.

Accelerating Potential—3000 volts.

Z-Axis Modulation—External terminal permits RC coupling to crt grid.

Graticule

Illumination—Variable edge lighting.

Display Area—Marked in 8 vertical and 10 horizontal 1 centimeter divisions with 2-millimeter markings on the center lines.

Power Supplies

Electronically regulated for stable operation with widely varying line voltages and loads.

Line Voltage Requirements—105 to 125 volts or 210 to 250 volts at 50-60 cycles. Will operate at line frequencies up to 800 cps with higher line voltages (see section 2).

Power Requirements—Approximately 110 watts.

Characteristics—Type RM503

Mechanical Specifications

Construction—Aluminum alloy chassis and cabinet.

Finish—Photo-etched anodized panel, blue vinyl-finish cabinet.

Dimensions—16½" deep, 19" wide, 7" high. (additional depth of 3" required for power cord).

ACCESSORIES

Information on accessories for use with this instrument is included at the rear of the mechanical parts list.

SECTION 2

PRELIMINARY INFORMATION

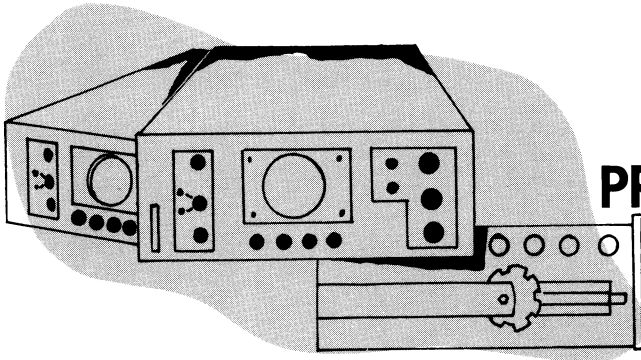

Power Requirements

The Type RM503 Oscilloscope line transformer primary can be wired for either 117-volt or 234-volt operation, at a line frequency of 50 to 60 cps. At this line frequency, proper regulation of the power supply will be obtained at line voltages between 105 volts and 125 volts when the line transformer is wired for 117-volt operation and between 210 volts and 250 volts when the line transformer is wired for 234-volt operation. Fig. 2-1 shows the transformer connections required for each range of operation.

The Type RM503 Oscilloscope can be operated at any ac line frequency from 50 cps up to 800 cps, although higher line voltages are required at the higher line frequencies. At an ac line frequency of 400 cps, the nominal and lower and upper limits are about 10% higher than at 50-60 cps. At a line frequency of 800 cps, the nominal and lower and upper limits are about 15% higher than at 50-60 cps. At line frequencies between the specific values given, the required line voltages will be proportionately larger or smaller. For maximum dependability and long life, it is recommended that the line voltage be kept at or slightly below the nominal.

Fuse Requirements

Use a 1.25-amp slow-blowing type fuse when the Type RM503 is wired for 117-volt operation. Use a 0.7-amp slow-blowing type fuse when the Type RM503 is wired for 234-volt operation.

Thermal Cutout

A thermal cutout switch in the primary circuit of the power transformer, T601, protects the Type RM503 from over-heating. If the internal temperature rises above the rating of the thermal switch, the switch will disconnect the power and keep it disconnected until the temperature drops to a safe value.

Rack Mounting

The Type RM503 is ready for mounting in a standard 19-inch open or enclosed relay rack.

To mount the instrument directly to either type of rack, first select four screws from the hardware kit whose threads match the threads of the mounting holes in the rack. Align the slots at the sides of the front panel with the holes in the rack, at the desired height. Fasten the instrument to the rack with four mounting screws, cup washers, and plastic washers. The plastic washers are inserted between the cup washers and the front panel to prevent the cup washers from cutting into the front panel when the screws are tightened.

Removal of Top and Bottom Panels

The top and bottom panels of the Type RM503 Oscilloscope are held in place by small flat-head screws. To remove the panels, first remove the screws. Then slide the panels back and lift free of the instrument. The panels can be replaced by reversing the order of removal.

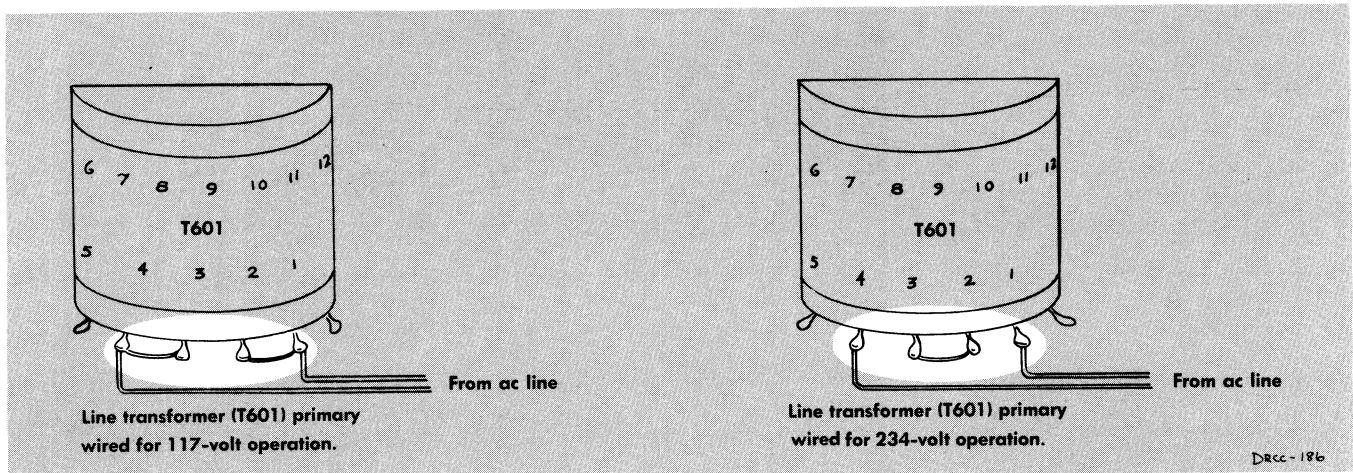
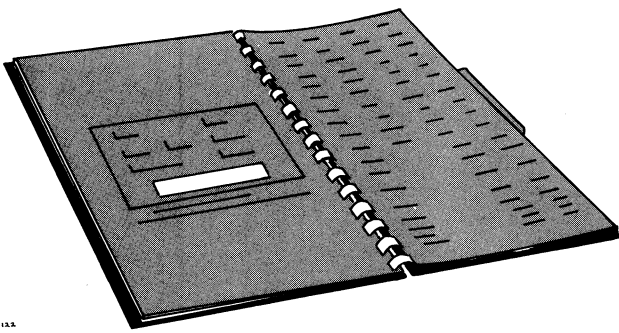

Fig. 2-1. Line transformer wired for 117- and 234-volt operation.

SECTION 3

OPERATING INSTRUCTIONS



Front Panel Controls and Connectors

The front panel of the Type RM503 Oscilloscope is shown in Fig. 3-1. Functions of all front panel controls and connectors are described in Table 3-1.

TABLE 3-1

SLOPE	Determines whether triggering occurs on rising portion (+ slope) or falling portion (— slope) of triggering waveform.
COUPLING	Selects whether triggering will occur at a specific dc level or at an ac level.
SOURCE	Selects the source of the triggering signal.
EXT. TRIG. IN	Input connector for external triggering signals.
LEVEL	Selects the voltage point on the triggering waveform at which the horizontal sweep is triggered. This control also selects automatic triggering (AUTO. position) or allows the sweep to free run (FREE RUN position).
SWEEP TIME/CM	Selects the desired horizontal sweep rate from a choice of 21 calibrated steps.
SWEEP TIME/CM VARIABLE (red)	Provides a continuous range of sweep rates between the fixed steps selected by the SWEEP TIME/CM switch. (The sweep rates are calibrated only when the Variable control is set fully clockwise to the CALIBRATED position.)
STABILITY ADJUST	Provides for a stable presentation when the LEVEL control is in the AUTO. position.
FOCUS	Focuses the trace or spot on the screen.
INTENSITY	Controls the brightness of the trace or the spot on the screen.
SCALE ILLUM.	Controls graticule illumination.
CAL. OUT connectors	Provide amplitude-calibrated square waves of 5 and 500 millivolts for use in calibrating gain of amplifiers.
HORIZONTAL DISPLAY	Selects conventional (horizontal sweep) or X-Y mode of operation. Also provides magnification of sweep rate selected by SWEEP TIME/CM control.
POWER	Applies and shuts off line power to the instrument.

VERTICAL CHANNEL

POSITION	Controls vertical positioning of the display on the screen.
SENSITIVITY	Selects the sensitivity of the Vertical Amplifier from 14 calibrated steps.
SENSITIVITY VARIABLE (red)	Provides a continuous range of sensitivity values between the fixed calibrated steps selected by SENSITIVITY control. (Normally, sensitivity is calibrated only when VARIABLE control is in CALIBRATED position.)
DC BAL.	Provides for vertical stability of no-signal trace for all positions of the SENSITIVITY control.
+ INPUT and — INPUT connectors	Input connectors for signal to be displayed vertically (Signals connected to the —INPUT connector will be displayed inverted).
+ INPUT and — INPUT switches	Select desired coupling for incoming signal.

HORIZONTAL CHANNEL

DC BAL.	Provides for horizontal stability of no-signal trace for all positions of SENSITIVITY control.
SENSITIVITY	Selects the sensitivity of the Horizontal Amplifier from 14 calibrated steps.
SENSITIVITY VARIABLE (red)	Provides a continuous range of sensitivity values between the fixed calibrated steps selected by the SENSITIVITY control. (Normally, sensitivity is calibrated only when VARIABLE CONTROL is in CALIBRATED position.)
POSITION	Controls horizontal positioning of the display on the screen.
+ INPUT and — INPUT connectors	Input connectors for signal to be displayed horizontally. (Signals connected to the —INPUT connector will be displayed inverted.)
+ INPUT and — INPUT switches	Select desired coupling for incoming signal.

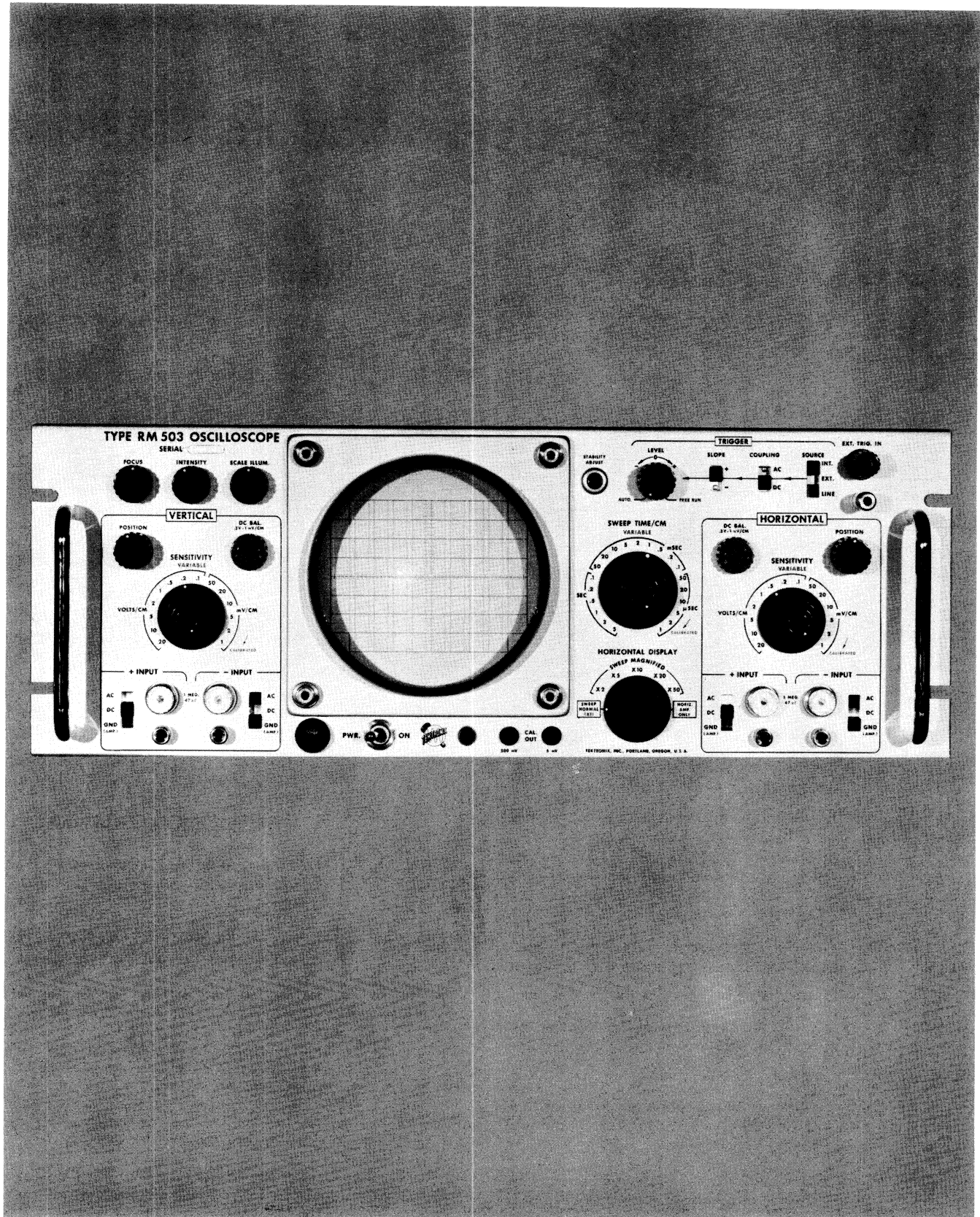

Fig. 3-1. Type RM503 Front panel.

PRELIMINARY INSTRUCTIONS

To initially set up the Type RM503 Oscilloscope for operation, proceed as follows:

1. Connect the oscilloscope to a suitable source of power (refer to Section 2 of this manual), and turn the POWER switch on. Set the INTENSITY control fully counterclockwise. Let the instrument warm up for about 5 minutes.
2. Set the HORIZONTAL DISPLAY switch to the HORIZ. AMPLIFIER position.
3. Set all of the INPUT switches to the GND position.
4. Set the two SENSITIVITY switches to .2 VOLTS/CM position and the SENSITIVITY VARIABLE controls to the CALIBRATED position (fully clockwise until they snap into position).
5. Set both POSITION controls to mid-range and advance the INTENSITY control to produce a spot on the screen. The INTENSITY control should be set to produce an easily seen, but not bright, spot. Too bright a spot may damage the phosphor on the face of the crt. The intensity should never be turned up to the point where a halo forms around the spot.
6. Adjust the FOCUS control to produce the smallest, roundest spot possible. Note the position of the spot on the crt.
7. Set the VERTICAL SENSITIVITY control to the 1 mV/CM position. Make sure that the SENSITIVITY VARIABLE control has remained in the CALIBRATED position.
8. With the VERTICAL DC. BAL. control, move the spot back to where it was in step 6.
9. Set the HORIZONTAL SENSITIVITY control to the 1 mV/CM position. Make sure that the SENSITIVITY VARIABLE control has remained in the CALIBRATED position.
10. With the HORIZONTAL DC. BAL. control, move the spot back to where it was in step 6.
11. Adjust both DC BAL. controls so that the spot does not move as the SENSITIVITY controls are moved from the .2 VOLTS/CM position to the 1 mV/CM position.

The amplifiers in the oscilloscope are now balanced and the oscilloscope is ready for operation as described in the remainder of this section.

Graticule Illumination

Graticule illumination can be adjusted to suit the lighting conditions of the room by means of the SCALE ILLUM. control. Turning the control clockwise increases the graticule illumination. It is possible to extinguish the graticule illumination completely by turning the control fully counter clockwise.

The graticule of the Type RM503 Oscilloscope can be illuminated so that it appears to have either red or white graticule markings. The markings can be changed from white to red or red to white simply by removing the graticule cover and inverting the graticule. As a general rule, white graticule lines are superior to red for photographic purposes.

INPUT SELECTION

Two INPUT connectors and associated INPUT switches are provided in each channel. When a single input is used, it may be applied through either the + INPUT or - INPUT connector. If the signal is connected to the + INPUT connector, the + INPUT switch should be placed in either the AC or DC position, depending upon the type of coupling desired. The - INPUT switch should be placed in the GND position. If the signal is connected to the - INPUT connector, the - INPUT switch should be placed in either the AC or DC position and the + INPUT switch should be placed in the GND position. It should be noted that when a signal is applied to the - INPUT connector of either channel, the display on the oscilloscope screen will be opposite in polarity to a normal presentation. Conventionally, a normal display places the more positive portions of a waveform in the vertical channel toward the top of the screen, and the more positive portions of a waveform in the horizontal channel toward the right-hand side of the screen.

When it is desired to display the difference between two signals, they are connected to the two INPUT connectors of the appropriate channel. In this case, both INPUT switches are placed in either the AC or DC positions. In this mode of operation, the two signals are subtracted from each other algebraically, and the difference is displayed as a single trace on the screen. This is called the "differential" mode of operation. It permits you to eliminate signals which are common to both inputs and to observe a waveform which is peculiar to one. Figs. 3-2 and 3-3 show the effects of application of signals to one or both INPUT connectors of the vertical channel.

The differential mode of operation also makes possible the observation of current changes in a circuit. The changes in the voltage drop across a given resistor are proportional to the changes in current through it. So a differential display of the voltages at the two ends of a resistor will show the changes in current through the resistor.

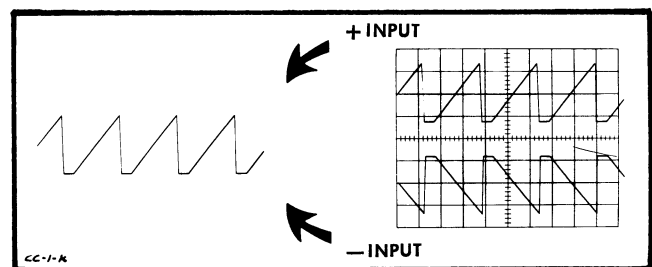

Fig. 3-2. Inputs to the vertical amplifiers.

Waveforms applied to the + INPUT connectors are displayed in the upright position, while waveforms applied to the - INPUT connectors are inverted.

Input Coupling

Input signals to both the vertical and horizontal channels can be either ac or dc coupled by placing the corresponding INPUT switches to the appropriate positions. Dc coupling applies both the ac and dc components of the input signal to the amplifier circuits. This permits you to measure the dc voltage level as well as the amplitude of the ac component.

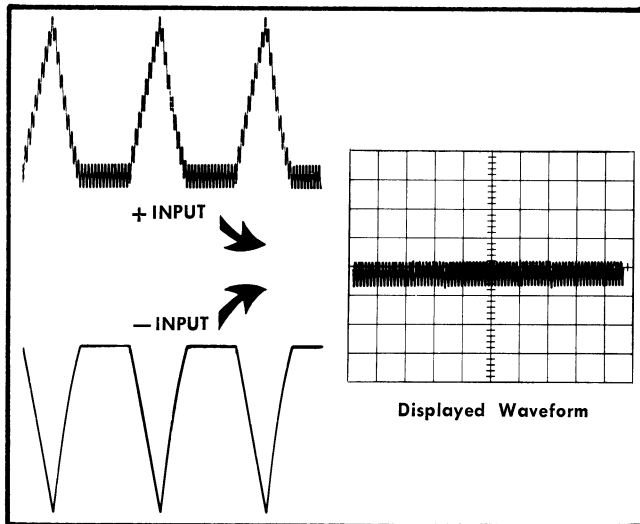

Fig. 3-3. Rejection of common mode signal by differential operation.
The signal applied to the — INPUT connector is algebraically subtracted from the signal applied to the + INPUT connector and the difference waveform is displayed on the crt screen.

However, it is sometimes neither necessary nor desirable to display the dc component, and in such cases ac coupling should be used. With ac coupling, a capacitor is placed in series with the input connector to block the dc component while allowing the ac component to be displayed.

CONVENTIONAL OSCILLOSCOPE OPERATION

Placing the HORIZONTAL DISPLAY switch in the SWEEP NORMAL position sets the Type RM503 Oscilloscope up for conventional oscilloscope operation. In this mode of operation, an internally generated horizontal sweep is applied through the horizontal amplifier to the horizontal deflection plates of the crt, and the input signal is applied through the vertical amplifier to the vertical deflection plates.

The Type RM503 Oscilloscope allows you to select, with the SWEEP TIME/CM control, any one of 21 calibrated sweep rates ranging in steps, from 1 microsecond to 5 seconds per centimeter. The SWEEP TIME/CM VARIABLE control makes it possible to obtain a continuous range of sweep rates between the steps selected by the SWEEP TIME/CM control. However, all sweep rates obtained with the SWEEP TIME/CM VARIABLE control in any position but full clockwise are uncalibrated.

Sweep Triggering

In order to obtain a stable display, it is necessary to start the horizontal sweep consistently at the same time relative to recurring cycles of the input waveform. The sweep therefore must be triggered by the input waveform itself or by some waveform which bears a fixed time relationship to the input waveform. The following instructions tell you how to select and use the proper triggering signal for various applications of the oscilloscope.

Selecting The Trigger Source

For most applications the sweep can be triggered by the input waveform. The only requirement is that the input signal be large enough to provide at least 0.5 centimeter of deflection on the screen at the sensitivity level for which the VERTICAL SENSITIVITY CONTROL is set. To obtain triggering of the sweep from the input waveform, set the SOURCE switch to the INT. position.

Sometimes it is advantageous to trigger the sweep with some external signal. This is especially true when the input waveform is of such small magnitude that it cannot provide stable triggering of the sweep by itself. External triggering is also useful where waveforms are going to be sampled from several different places within a device. By using external triggering, it is not necessary to reset the triggering controls each time a new waveform is shown. In order to obtain a stable display, it is necessary that the external waveform bear a fixed time relationship to the input waveform. To use an external waveform for triggering the horizontal sweep, connect the signal to the EXTERNAL TRIG. IN connector and set the SOURCE switch to the EXT. position.

When you are observing a waveform which bears a fixed time relationship to the line frequency, you may wish to trigger the sweep from the line-frequency waveform. To do this, place the SOURCE switch in the LINE position.

Selecting The Trigger Coupling

For most recurrent waveforms, ac coupling of the triggering signal (COUPLING switch in the AC position) will provide satisfactory triggering of the sweep. Dc coupling of the triggering signal (COUPLING switch in the DC position) is particularly useful in triggering from random pulse trains or very low frequency waveforms. With dc coupling the sweep is triggered by an instantaneous dc voltage. With ac coupling the sweep is triggered when the signal reaches a given amplitude from its average dc level.

Selecting The Trigger Slope

When the SLOPE switch is in the + position, the sweep is triggered on a positive-going slope of the triggering signal. When the SLOPE switch is in the — position, the sweep is triggered on a negative-going slope of the triggering signal. In most cases, selection of the triggering slope is not critical since triggering on either slope will provide a display which is suitable.

Selecting The Trigger Level

The LEVEL control determines the instantaneous voltage level (ac or dc, depending upon the setting of the COUPLING switch) on the triggering signal at which the sweep is triggered. With the SLOPE switch in the + position, adjustment of the LEVEL control makes it possible to trigger the sweep consistently at virtually any point on the positive-going slope of the triggering signal. Likewise, with the SLOPE switch in the — position, adjustment of the LEVEL control makes it possible to trigger the sweep consistently at vir-

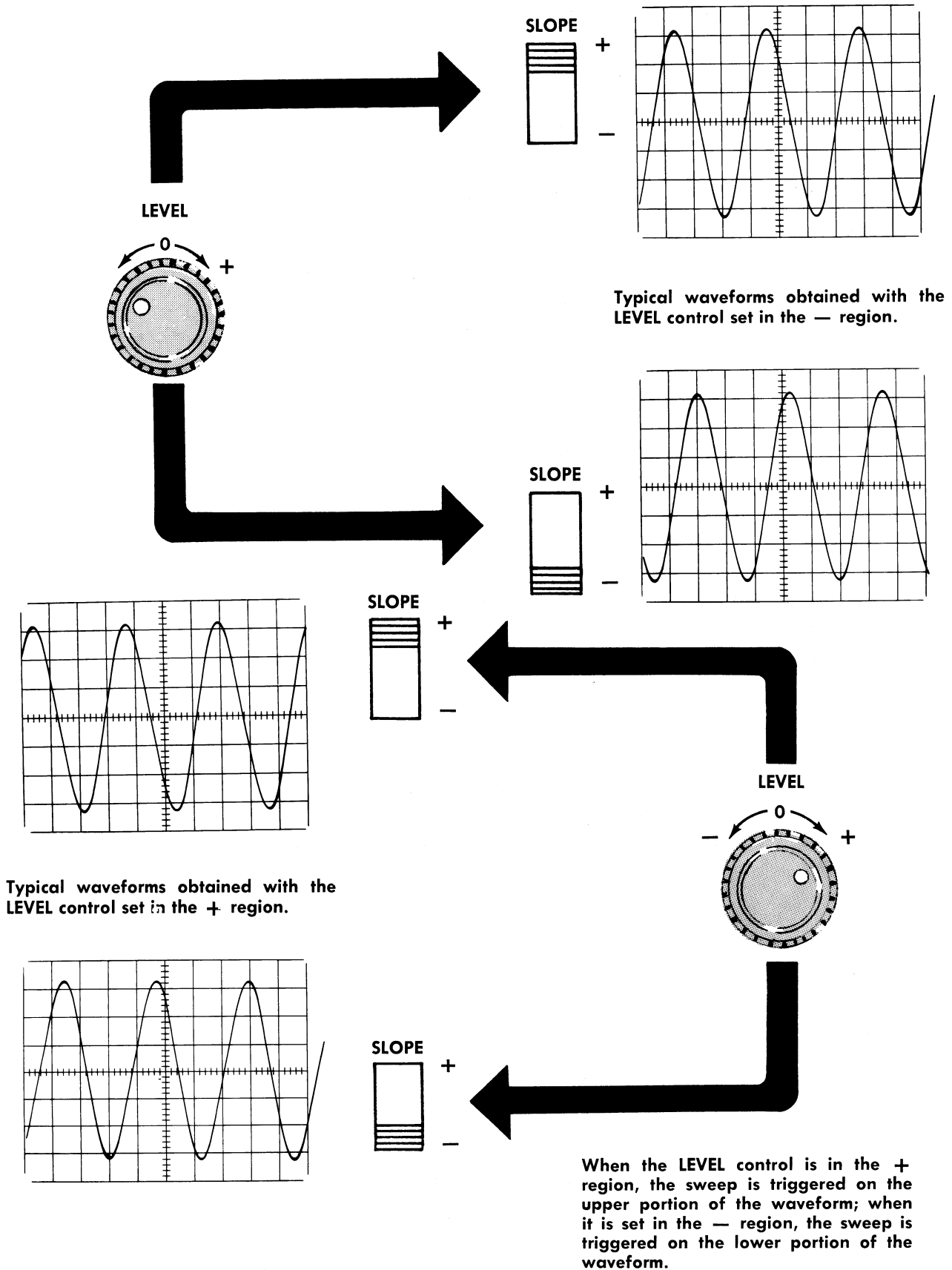

Fig. 3-4. Effects of the LEVEL control and SLOPE switch.

Operating Instructions—Type RM503

tually any point on the negative-going slope of the triggering signal. Fig. 3-4 shows the effects of the LEVEL control and the SLOPE switch.

At the extreme clockwise and counterclockwise ends of its range, the LEVEL switch activates, respectively, the FREE RUN and AUTO. switches. The effects of these switches are discussed in the following paragraphs.

Automatic Mode of Operation

Setting the LEVEL control fully counterclockwise to the AUTO. position sets the Type RM503 Oscilloscope up for an automatic mode of triggering which is suitable for most applications. In this mode, the triggering signal is ac coupled, and the triggering level is automatically set such that any external triggering signal of one volt or more, or internal triggering signal which would produce 1 centimeter or more of deflection on the crt screen, will trigger the sweep. In the absence of such a triggering signal, the sweep will continue to be triggered automatically at about a 50-cps rate to produce a base line which indicates that the instrument is adjusted to display any signal which might be connected to the vertical channel.

Free-Running Mode of Operation

Setting the LEVEL control fully clockwise to the FREE RUN position produces a free-running sweep, independent of any synchronizing signal. The frequency of the free-running sweep is dependent upon the setting of the SWEEP TIME/CM control. This free-running trace is useful as a base line from which to make dc measurements when the input signal is dc coupled.

Magnification of the Sweep

Any part of the trace may be expanded horizontally by as much as 50 times through the use of the SWEEP MAGNIFIED portion of the HORIZONTAL DISPLAY switch. To expand a given portion of the sweep, first set that portion to the center of the graticule by means of the HORIZONTAL POSITION control. Then set the HORIZONTAL DISPLAY switch to the desired degree of magnification.

In magnified sweep operation, the sweep rate is multiplied by the setting of the HORIZONTAL DISPLAY switch. This means that the SWEEP TIME/CM setting must actually be divided by the setting of the HORIZONTAL DISPLAY switch to obtain the correct time for the sweep to move one centimeter. For example, if the SWEEP TIME/CM is set to 5 μ SEC and the HORIZONTAL DISPLAY switch is set to X10, the true sweep rate is 0.5 micro-second or 500 nanoseconds per centimeter.

It should be noted that with combinations of the SWEEP TIME/CM control and the HORIZONTAL DISPLAY switch which produce sweep rates faster than about 0.1 micro-second per centimeter, the calculated sweep rates should not be depended upon to be accurate enough to base time measurements on them.

X-Y MODE OF OPERATION

Placing the HORIZONTAL DISPLAY switch in the HORIZ. AMP. ONLY position sets the Type RM503 Oscilloscope up for X-Y operation. In this mode of operation, input signals are applied to both the horizontal and vertical amplifiers, and the display is a graph of the waveform on one channel versus the waveform on the other channel. The horizontal sweep is disabled. Examples of the use of the X-Y mode of operation are the plotting of hysteresis loops, of voltages across a semiconductor versus deformation or strain in a material. Use can still be made of the differential input feature on one or both channels.

APPLICATIONS

The following paragraphs describe procedures for making measurements of voltage, elapsed-time, and phase-shift with the Type RM503 Oscilloscope. No attempt has been made to describe any but the most basic techniques. Familiarity with the instrument will enable the operator to apply the essence of these techniques to a wide variety of applications, depending upon the problem at hand.

Voltage Measurements

To measure the ac component of a signal, proceed as follows:

1. Display the waveform over as large a portion of the screen as possible by adjusting the appropriate SENSITIVITY control.
2. With the aid of the graticule, measure the distance (in centimeters) between the two points on the waveform between which the voltage measurement is desired. This will be a vertical measurement where the waveform to be measured is applied to the vertical channel, a horizontal measurement where the waveform to be measured is applied to the horizontal channel. Make sure that the appropriate VARIABLE control is in the CALIBRATED position. On small voltage measurements, the width of the trace can make up an appreciable part of the entire measurement. For this reason, it is important to take all readings in a given measurement from the same side of the trace.
3. Multiply the distance between the two points by the setting of the appropriate SENSITIVITY control and by the attenuation factor, if any, of the probe. This is the voltage between the two points on the waveform.

To measure the dc level at some point on a signal, proceed as follows:

1. Set the INPUT switch associated with the INPUT connector to which the signal is connected to the GND position.
2. If the horizontal sweep is being used, rotate the LEVEL control fully clockwise to the FREE RUN position to produce a free-running trace. If the oscilloscope is being used in the X-Y mode of operation, the signal on the other channel will produce a trace.
3. With the appropriate POSITION control, position the trace so that it lies along one of the lines of the graticule.

This line will be used as a ground reference line; its position in any given case will depend upon the polarity and amplitude of the input signal to be measured. Do not adjust this POSITION control after the reference line has been established.

4. Set the INPUT switch mentioned in step 1 to the DC position. If the horizontal sweep is being used, adjust the LEVEL control for a stable display.

5. Measure the distance, in centimeters, from the ground reference line established in step 3 to the point at which the dc voltage level is desired.

6. Multiply this distance by the setting of the appropriate SENSITIVITY control and the attenuation factor, if any, of the probe. This is the dc level of the point measured.

Time and Frequency Measurements

To measure the time interval between two points on a waveform, proceed as follows:

1. Set the oscilloscope up for conventional operation with the signal applied to either of the vertical INPUT connectors.

2. With the aid of the graticule, measure the horizontal distance, in centimeters, between the two points whose intervals you wish to find. Make sure that the SWEEP TIME/CM VARIABLE control is in the CALIBRATED position.

3. Multiply the distance measured by the setting of the SWEEP TIME/CM control and divide by the setting of the HORIZONTAL DISPLAY switch (X1, X2, X5, etc.). This is the time interval between the two points measured.

To determine the frequency of a recurrent waveform, simply take the reciprocal of the time interval between corresponding points on two consecutive cycles of the waveform.

Phase-Shift Measurements

To measure the phase shift produced in a given signal by some device, proceed as follows:

1. Set the oscilloscope up for conventional externally triggered operation with the signal at the input to the phase-shifting device applied to either of the vertical INPUT connectors.

2. Horizontally position the display so that an easily identifiable point of a cycle corresponds to one of the vertical graticule lines.

3. Without making any adjustments to the oscilloscope, move the signal probe from the input to the output of the device under test. You will find that the display has shifted horizontally.

4. Measure the amount of horizontal shift of the display in centimeters.

5. Measure the distance in centimeters between corresponding points on two consecutive cycles of the waveform.

6. Divide the measurement obtained in step 4 by the measurement obtained in step 5 and multiply the result by 360° . This is the phase shift produced in the signal by the device under test.

A second method for comparing the phase relationship of two signals of the same frequency makes use of the X-Y mode of operation. This method is suitable only when comparing two sine waves.

1. Apply the sine waves to the two + INPUT connectors. The display will be an ellipse. (Actually, the display will appear as a diagonal straight line if the two sine waves are in phase or exactly 180° out of phase, or it will appear as a circle if the two sine waves are exactly 90° or 270° out of phase. Application of these instructions, however, will still apply.)

2. Center the ellipse horizontally and vertically on the crt screen.

3. Measure the distances A and B on the display as shown in Figure 3-5.

A/B is equal to the sine of the phase difference between the two signals.

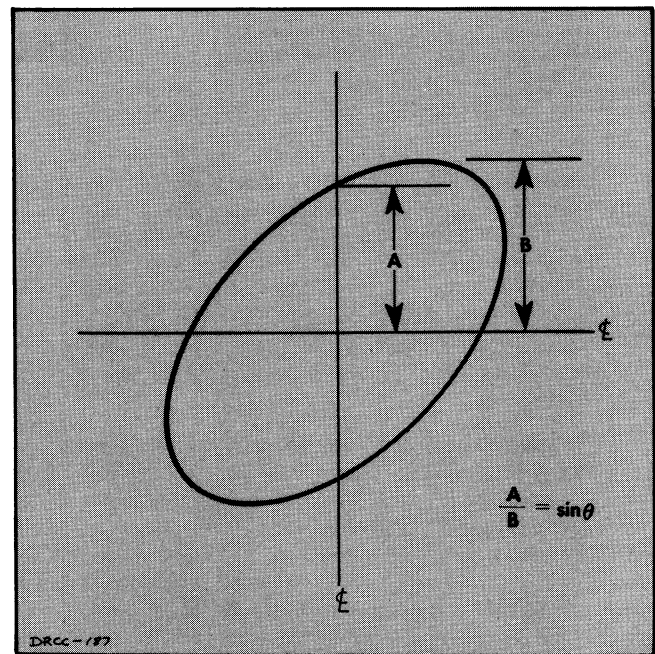

Fig. 3-5. X-Y method of calculating phase difference (θ) of two sine waves.

Direct Connection to the CRT Plates

In some applications it may be desirable to connect a signal directly to one or both sets of crt deflection plates, bypassing the internal oscilloscope amplifiers. The vertical deflection plate pins are located on the side of the neck of the crt, and the horizontal deflection plate pins are located at the top of the neck of the crt.

With a signal connected directly to the crt pins, it is possible, under optimum impedance matching conditions and with connections kept as short as possible, to obtain a bandwidth on the order of 100 mc with the Type RM503. However, limitations of the sweep magnifier at the faster sweep rates discussed earlier in this section must be kept

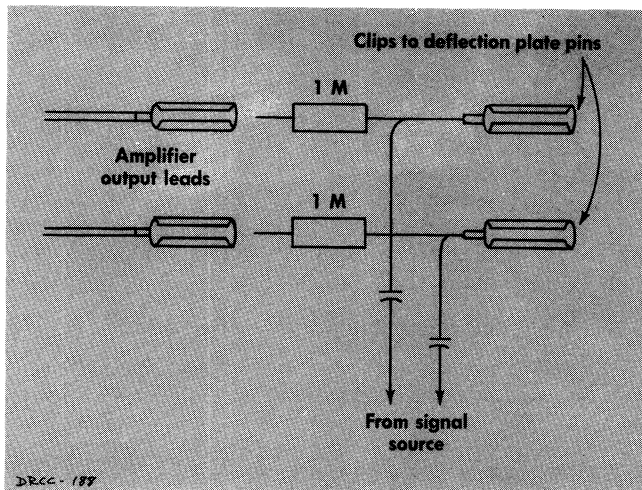

Fig. 3-6. Typical circuit for ac coupling to the crt deflection plates.

in mind when making risetime measurements on fast-rise waveforms. The vertical and horizontal deflection factors of the crt are approximately 22 volts per centimeter and 18 volts per centimeter, respectively.

The diagram in Fig. 3-6 shows how a signal may be ac coupled to the crt deflection plates. This method of ac coupling permits the use of front panel controls to position the display on the screen. The SENSITIVITY control of the bypassed amplifier should be placed in the 20 VOLTS/CM position, and both INPUT switches should be placed in the GND position. The value of the capacitors shown in Fig. 3-6 will depend upon the characteristics of the signal to be displayed.

To dc couple a signal to the deflection plates, remove the amplifier leads and connect the signal directly to the crt pins. It is a good idea to tape the ends of the loose amplifier leads to prevent accidental shocks to operating personnel. For best performance, the average of the voltages at the two plates must be kept to +150 volts; otherwise, the display will be defocused and slightly bowed, and the sweep rate, if the sweep is used, will not be accurate. Actually, if these effects can be tolerated, it is possible to have both plates in the vicinity of ground and still obtain a useful display. Typically, the sweep rate is about 8% slow when a ground level signal is connected to the vertical deflection pins.

Care should be exercised in connecting and disconnecting the crt pin leads as the pins can be easily bent or broken.

USE OF PROBES

Use of an attenuator probe with the Type RM503 will reduce the capacitive and resistive loading on a circuit

under test, but at the same time will also reduce the sensitivity.

Connected to an input connector of the Type RM503, a Tektronix probe presents a characteristic input impedance of 10 megohms paralleled by from 8 to 14 $\mu\mu\text{f}$ (depending on the probe) and has an attenuation of 10:1. The maximum voltage rating of a Tektronix probe is 600 volts. Exceeding this rating, either in dc volts or peak ac volts, may damage the probe.

When making amplitude measurements with an attenuator probe, be sure to multiply the observed amplitude on the crt by the attenuation factor of the probe. If the waveform being displayed contains fast-changing signals, it will generally be necessary to clip the probe ground lead to the chassis of the equipment under test.

Probe Compensation

An adjustable capacitor in all Tektronix probes is used to compensate for variations in input capacitance from one instrument to another, or between two input connectors of one instrument. To insure the accuracy of pulse and transient measurements always check the compensation before using a probe. To check or adjust the probe compensation, display several cycles of the Calibrator waveform on the crt by connecting a test lead between the 500 mV CAL. OUT connector and the VERTICAL + INPUT connector. For this display set the VERTICAL SENSITIVITY control to .1 VOLTS/CM, the + INPUT switch to DC, and the - INPUT switch to GND.

Carefully observe the waveform display on the crt, and particularly note the general shape of the leading corner of each positive pulse. Then disconnect the test lead between the CAL. OUT and + INPUT connectors, and connect the probe to the + INPUT connector. Square waves having the same amplitude as the previous display should now appear on the crt. Carefully adjust the probe capacitance, if necessary, until the leading corners of the positive pulses have the same shape as those in the previous display.

To compensate the probe on the horizontal channel, a sawtooth sweep voltage must be applied to the vertical channel to obtain a vertical display of the calibrator waveform. The displayed waveform will then appear somewhat similar to that shown in Fig. 6-5. However, if both the horizontal and vertical input capacitances are adjusted correctly (47 $\mu\mu\text{f}$), a probe compensated on the vertical channel will function properly on the horizontal channel. The procedure for checking the input capacitance is given in Section 6 under "High Frequency Compensation."

SECTION 4

CIRCUIT DESCRIPTION

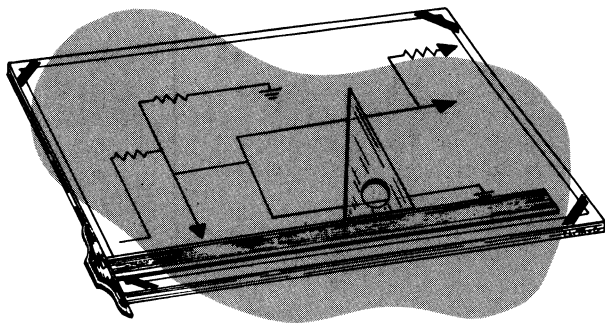

VERTICAL AMPLIFIER

General Description

The Vertical Amplifier consists of two opposing input circuits and two dc-coupled, push-pull amplifiers. The maximum overall gain of the Vertical Amplifier is on the order of 25,000, which provides the required 25 volts per centimeter of deflection at the crt from each millivolt of signal at the inputs (with the SENSITIVITY control in the 1 mV/CM position).

The Input Amplifier consists of two stages, a cathode-coupled paraphase amplifier stage and a pair of transistors. The combined gain of the two stages is controlled by negative feedback. The output from the Input Amplifier drives the Output Amplifier which, in turn, drives the crt deflection plates. Changes in Vertical Amplifier sensitivity are accomplished by input attenuation and by negative feedback in the Input Amplifier. Vernier attenuation is accomplished by degeneration in the cathode circuit of the Output Amplifier.

Input Circuits

The two input circuits allow the Input Amplifier to be operated either as a single-ended cathode-coupled paraphase amplifier or as a differential amplifier. For single-ended operation, the signal is applied to one of the two input connectors and the other is grounded. For differential operation, signals are applied to both input connectors and the amplifier amplifies the difference between them. The two input switches permit both inputs to be either ac or dc coupled, or one ac coupled and the other dc coupled. The lower bandpass limit of the inputs when ac coupled is about 7.5 cps.

In the 1 mV/CM to .2 VOLTS/CM positions of the SENSITIVITY control, the signal is applied "straight through" to the grid circuit, or circuits, of the Input Amplifier; the changes in sensitivity are accomplished by changes in negative feedback within the amplifier. In the .5 VOLTS/CM to 2 VOLTS/CM positions of the SENSITIVITY control, a X10 attenuator is inserted in the input circuits and the negative feedback values of the 1 mV/CM to .2 VOLTS/CM positions are repeated. In the 5 VOLTS/CM to 20 VOLTS/CM positions, a X100 attenuator is inserted in the input circuits and the negative feedback values are repeated again.

The attenuators are both resistance and capacitance dividers. For dc and low frequency signals, the attenuators act purely as resistance dividers, since the impedance of the capacitors is so high that it can be neglected. For higher

frequency signals, however, the impedance of the capacitors is less, and their effect on the circuit is more pronounced. Near the upper-frequency range of the amplifier, the impedance of the capacitors becomes so low, compared to the resistance of the circuit, that the attenuators become capacitance dividers.

In addition to providing the proper degree of attenuation, the resistance values of the attenuators are chosen so as to provide a constant 1 M input resistance, regardless of the setting of the SENSITIVITY control. The capacitance of the attenuators is also adjusted to provide a constant input capacitance of 47 $\mu\mu\text{f}$ regardless of the setting of the SENSITIVITY control.

Input Amplifier

The Input Amplifier amplifies the potential difference between the two grids of V434. When one grid goes positive and the other goes negative with respect to ground, the output of the stage is proportional to the sum of the amplitudes of the two signals. When both grids go positive or both go negative, the output is proportional to the difference between the amplitudes of the two signals. In single ended operation, a signal is applied to one grid while the other grid circuit is grounded; therefore, the output is proportional to the amplitude of the one signal applied. The output of V434, then, is a push-pull signal to the bases of the transistors, Q454 and Q464, regardless of whether the Input Amplifier is being operated single-ended or differentially.

The gain of the Input Amplifier is varied (in steps) by changing the value of R408. This varies the amount of negative feedback applied to the cathode circuit of the first stage from the output of the second. This feedback is applied through R457 and R467 to the parallel network of R419 and L419 (in series) and R408. As the value of R408 is increased, the amount of negative feedback voltage is increased, limiting the gain of the amplifier. Dc balance of the Vertical Amplifier is accomplished by means of the COARSE DC BAL. (VERT.) control and the DC BAL. control. Proper adjustment of these two controls sets the two ends of R408 at the same potential so that there is no current flowing through it. This provides vertical stability of the trace throughout the range of the SENSITIVITY control.

The second stage of the Input Amplifier is provided with a positive feedback path from the collector of each side to the base of the other. This positive feedback path is adjusted, by varying the value of R460, to set this second stage for infinite gain. Thus, the second stage provides its own driving current and none is diverted from the plate circuits of the first stage. The negative feedback through the first stage

Circuit Description—Type RM503

of the amplifier prevents the infinite-gain second stage from oscillating. The effect of R460 is most pronounced in the 1 mV/CM position of the SENSITIVITY control since there is the least amount of overall negative feedback in this position.

Output Amplifier

The Output Amplifier is the stage that drives the vertical deflection plates of the crt. The gain of this stage can be adjusted by means of the .2 V GAIN. ADJ. (VERT.), R478, and the VARIABLE control, R488.

Vertical positioning of the crt beam is accomplished by means of the cross-coupled dual POSITION control, R470. Adjustment of this control varies the current through the Output Amplifier tubes thereby changing the average dc voltage at each of the plates inversely to the other. At the same time, through feedback in the Input Amplifier, the control also produces a small push-pull change in voltage at the grids of the Output Amplifier to maintain the cathodes at the same potential as the current is changed.

Trigger Pickoff

The output from V474, one side of the Output Amplifier, is applied through a divider network made up of R490, R491, and R492 to the SOURCE switch, SW5. Thus, when the SOURCE switch is in the INT. position, the output of the Output Amplifier is applied to the Sweep Trigger to start the Horizontal sweep.

HORIZONTAL AMPLIFIER

X-Y Operation

When the Type RM503 Oscilloscope is set for X-Y operation (HORIZONTAL DISPLAY switch in the HORIZ. AMP. ONLY position), the Horizontal Amplifier is virtually identical to the Vertical Amplifier. A given signal or signals applied to the Horizontal Amplifier inputs will produce the same deflection as the same signal or signals applied to the Vertical Amplifier inputs, except, of course, that the deflection will be in the X (horizontal) plane rather than the Y (vertical) plane. This mode is used for plotting two voltage functions against one another.

Sweep Operation

When the Type RM503 Oscilloscope is set up for sweep operation, the Horizontal Amplifier is used to amplify the sawtooth waveform from the Sweep Generator. In this mode of operation the Horizontal Input Amplifier is connected for single-ended operation. The sawtooth waveform is applied to one grid of the Input Amplifier and the other grid is grounded. Neither of the input attenuators is used.

The feedback circuits which control the gain of the Horizontal Amplifier operate in the same manner for sweep operation as for X-Y operation, except that a different set of resistors is used in the Input Amplifier cathode circuit.

Also the VARIABLE control in the cathode circuit of the Output Amplifier is shorted out. In sweep operation, the POSITION control varies the dc potential on the active grid of the Input Amplifier rather than the current through the two halves of the Output Amplifier.

SWEEP TRIGGER

The Sweep Trigger circuit consists of the Trigger Input Amplifier, V24, and the Trigger Multivibrator, V45. The Trigger Input Amplifier amplifies (and, when desired, inverts) the incoming triggering signal and applies it to the input of the Trigger Multivibrator. The Trigger Multivibrator produces a negative-going rectangular pulse whose leading edge is coincident with the point on the triggering signal at which it is desired to start the horizontal sweep. This leading edge is then differentiated to produce a sharp negative spike which triggers the Sweep Generator.

Trigger Source

The triggering signal from which the rectangular output pulse is produced may be obtained from any one of three sources. When the SOURCE switch is in the INT. position, the signal is obtained from the Trigger Pickoff circuit of the Vertical Amplifier. When the SOURCE switch is in the EXT. position, the signal may be obtained from an external source through the EXTERNAL TRIG. IN connector on the front panel. When the SOURCE switch is in the LINE position, the signal is obtained from one side of the 6.3 volt ac filament heater circuit.

Trigger Slope

The negative-going pulse is initiated at the output of the Trigger Multivibrator (plate of V45B) only when there is a Negative-going signal at the input of the Trigger Multivibrator (grid of V45A). However, it is desired to be able to start the sweep during either a positive-going or negative-going portion of the triggering signal. Therefore, some provision must be made for choosing between inverting or not inverting the triggering signal in the Trigger Input Amplifier. This is done by means of the SLOPE switch.

With the SLOPE switch in the — position, V24 is a cathode-coupled amplifier and the triggering signal is applied to the grid of V24A. The signal at the plate of V24B is in phase with the incoming triggering signal. Thus, the negative-going portion of the signal at the input to the Trigger Multivibrator corresponds to the negative-going portion of the incoming triggering signal. With the SLOPE switch in the + position, the triggering signal is applied to the grid of V24B, and V24B becomes an ordinary plate-loaded amplifier. The signal at the plate of V24B is opposite in polarity from the incoming triggering signal. Thus, the negative-going portion of the signal at the input to the Trigger Multivibrator corresponds to the positive-going portion of the incoming triggering signal.

Trigger Level

The LEVEL control, R17, varies the bias on the tube to which it is connected. This in turn varies the quiescent volt-

age at the plate of V24B about which the signal varies. Since the Trigger Multivibrator is triggered at a given dc level, varying the dc voltage about which the triggering signal varies in effect varies the instantaneous voltage level of the signal at which the Trigger Multivibrator is triggered. Thus, through the use of the SLOPE and LEVEL switches it is possible to trigger the Trigger Multivibrator at virtually any point on either a positive-going or negative-going portion of the triggering signal.

Triggering Multivibrator

The Trigger Multivibrator operates as follows: In the quiescent state, that is, ready to receive a signal, V45A is conducting and its plate voltage is down. This holds the grid of V45B below cutoff, since the two circuits are dc-coupled. With V45B in a state of cutoff, its plate voltage is up.

The negative-going portion of the signal from the Trigger Amplifier drives the grid of V45A in a negative direction, and the cathodes of both tubes follow the grid down. At the same time the plate voltage of V45A starts to rise. This causes the grid voltage of V45B to rise. With the grid of V45B going up and its cathode going down, V45B starts to conduct. As V45B starts conducting, its cathode starts going up, taking the cathode of V45A up with it. With the grid of V45A down and its cathode up, V45A cuts off. This causes the plate of V45A, and therefore the grid of V45B, to go farther in a positive direction, and causes V45B to conduct heavily. This creates a negative step at the plate of V45B. The transition occurs very rapidly, regardless of how slowly the signal at the grid of V45A falls initially.

When the signal at the grid of V45A goes in the positive direction, just the opposite chain of events will occur. V45A will start conducting again, and V45B will cut off. The result is a positive step at the plate of V45B. This step is also differentiated to form a positive spike but this spike is bypassed to the +250-volt supply by D44 and is not used.

Automatic Triggering

When the LEVEL control is turned fully counterclockwise, the AUTOMATIC switch, SW17, is activated and converts the Trigger Multivibrator from a bi-stable configuration to an astable (free-running) configuration. (This should not be confused with the action of the FREE RUN switch, shown on the Sweep Generator diagram, which causes the Sweep Generator to free-run). This is accomplished by coupling the grid circuit of V45B to the grid circuit of V45A via R40. In addition, the dc coupling between the Trigger Input Amplifier and the Trigger Multivibrator is removed when the switch is in this position.

To understand the operation of the Trigger Multivibrator in the free-running mode of operation, first assume that V45B is cut off and V45A is just being driven into cutoff by the charge on C31. The voltage at the plate of V45A starts to rise, carrying with it the voltage at the grid of V45B. So V45B starts to conduct, causing a negative step at its plate. Since the two grids are coupled through R40, the grid of V45A will start moving positively at the same time as does the grid of V45B. However, the time constant of the R40-C31 network is such that it takes about 0.01

second for the voltage at the grid of V45A to rise exponentially from its starting point, below cutoff, to a point where the tube will start conducting.

When V45A does start conducting, its plate voltage will drop, carrying with it the grid of V45B. V45B will cut off, causing a positive step at its plate. At the same time that the grid of V45B goes negative, the grid of V45A will also start negative. Once again, it will take about 0.01 second for C31 to charge up sufficiently to cut V45A off. When V45A does cut off, the cycle starts over.

Hence, in the absence of a triggering signal, the Trigger Multivibrator free-runs at about 50 cps. However, since the triggering signals from the Trigger Input Amplifier are still coupled to the Trigger Multivibrator through C31, any triggering signal over 50 cps in frequency will produce synchronized operation of the Trigger Multivibrator. The 50 cps free-running sweep produced in the absence of a triggering signal provides a base line from which to make voltage measurements and also indicates that the instrument is adjusted to display any signal that might be applied to the input.

SWEEP GENERATOR

The Sweep Generator, upon receipt of a trigger pulse from the Sweep Trigger, produces a linearly rising (sawtooth) voltage which is applied through the Horizontal Amplifier to the crt deflection plates. This causes the spot to move from left to right on the crt screen and form the sweep. The amplitude of the sawtooth voltage is about 100 volts. Its rate of rise is controlled by the values of the Timing Capacitor and Timing Resistor switched into the circuit by the SWEEP TIME/CM switch on the front panel.

The Sweep Generator consists of three main circuits; the Sweep-Gating Multivibrator, the Miller Runup Circuit, and the Hold-Off Circuit. The Sweep-Gating Multivibrator consists of V135A, V135B and V145A. The essential components of the Miller Runup Circuit are: the Miller Runup Tube, V160A; the Runup Cathode Follower, V160B; the Disconnect Diodes, V152A and V152B; the Timing Capacitor, C160; and the Timing Resistor, R160. The Hold-Off Circuit consists of the Hold-Off Diode, V152C; the Hold-Off Cathode Follower, V145B; the Hold-Off Resistor, R181; and the Hold-Off Capacitor, C160 (the Hold-Off Circuit makes use of some of the same timing capacitors as the Miller Runup Circuit).

In the quiescent state, that is, when no sweep is being generated, V135A is conducting and V145A is cut off. The plate of V145A is at about -2.5 volts with respect to ground. The Disconnect Diodes are conducting and hold both sides of the Timing Capacitor at about -2.5 volts. With its cathode grounded and its grid at -2.5 volts, V160A is conducting heavily and its plate is at about +30 volts.

Sweep Generation

A negative trigger pulse, arriving at the grid of V135A from the Sweep Trigger circuit, causes the Sweep Gating Multivibrator to switch rapidly to its other state. That is, V135A cuts off and V145A conducts. As V145A conducts, its plate voltage goes down, cutting off the Disconnect Diodes. When the Disconnect Diodes cut off, the plates of

Circuit Description—Type RM503

the Timing Capacitor are no longer held at -2.5 volts, and the Timing Capacitor starts to charge toward the instantaneous potential difference between the -100 -Volt supply and the potential on the cathode of V160B. However, as the lower plate of the Timing Capacitor starts to move in a negative direction, it takes the grid of V160A with it. This produces a positive swing at the plate of V160A which is coupled, through B167 and V160B, to the upper plate of the Timing Capacitor. This increases the voltage to which the Timing Capacitor is trying to charge. The effect is to "straighten out" the charging curve by increasing the charging voltage with each increment of charge on the capacitor. The positive voltage swing on the upper plate of the Timing capacitor also tends to prevent the lower plate from swinging negatively. Since the gain of V160A is about 200, the potential on the upper plate moves about 100 volts with respect to ground while the potential on the lower plate moves about one-half volt. The result is an extremely linear ramp at the cathode of V160B, which is applied through the Horizontal Amplifier to the horizontal deflection plates of the crt.

Sweep Length

The length of the sweep, that is, the distance the spot moves across the crt, is determined by the setting of the SWP. LENGTH control, R176. As the sweep voltage rises linearly at the cathode of V160B, there will be a linear rise in the voltage at the wiper arm of the SWP. LENGTH control. This will increase the voltage at the plate, and therefore the cathode, of V152C and at the grid and cathode of V145B. As the voltage at the cathode of V145B rises, the voltage at the grid of V135A will rise. When the voltage at this point rises to a point where V135A comes out of cutoff, the Sweep-Gating Multivibrator will rapidly revert to its original state with V135A conducting and V145A cut off. The voltage at the plate of V145A will then rise, carrying with it the voltage at the plates of the Disconnect Diodes.

V152B starts conducting, and brings the grid of V160A quickly back up to its quiescent level. The rise in voltage at the grid causes the tube to conduct more, so the plate voltage drops, carrying with it the grid and cathode of V160B. When the voltage at the cathode of V160B returns to about -2.5 volts, V152A conducts, clamping the voltage at this point. The circuit has now returned to its quiescent level and is ready for the next trigger.

Hold-Off

The Hold-Off Circuit prevents the Sweep Generator from being triggered during the sweep retrace interval. It does this by holding the grid of V135A positive enough to keep V135A in conduction until after the Miller Runup Circuit has stabilized in the quiescent condition.

Under quiescent conditions, normal conduction through V152C allows the Hold-Off Capacitor, C160, to be charged to about 70 volts. During the latter part of the sweep, the rising voltage at the cathode of V152C discharges this capacitor to a lower voltage, in the vicinity of about 55 volts. At the end of the sweep, when the voltage at the cathode of V160B drops, the voltage at the SWP. LENGTH wiper arm also drops and V152C cuts off. The cathode tries

to follow the drop in voltage at the plate but is held up by the charge on the Hold-Off Capacitor. The Hold-Off Capacitor charges again exponentially toward 100 volts, carrying the cathode of V152C and the grid of V145B negative. The cathode of V145B, and therefore the grid of V135A, follows the grid of V145B. At some point in this exponential charging curve, depending upon the settings of the STABILITY ADJUST control and the FREE RUN switch, the grid of V135A will become negative enough that a negative trigger pulse coming from the Sweep Trigger circuit can again take V135A into cutoff.

The hold-off time, then, is determined by the value of C160 switched into the Hold-Off Circuit by the SWEEP TIME/CM switch. The amount of hold-off time required is determined by the sweep rate. For this reason the SWEEP TIME/CM switch changes the amount of capacitance in the Hold-Off Circuit simultaneously with that in the Timing Circuit.

Sweep Stability

The STABILITY ADJUST control, R111, regulates the dc level at the grid of V135A. This control is adjusted so that the voltage at the grid of V135A is just high enough to prevent the circuit from free running. When it is adjusted in this manner, a sweep can be produced only when a negative trigger pulse from the Sweep Trigger can drive V135A into cutoff. Turning the LEVEL switch full clockwise closes the FREE RUN switch and shorts out R111. This places a more negative voltage on the grid of V135A such that V135A cuts off immediately upon decay of the hold-off voltage, at which time the next sweep is initiated. The result is a free-running sweep whose period is the total of the sweep time plus the hold-off time at any given setting of the SWEEP TIME/CM switch. (This is compared to a maximum repetition rate of about 50 cps when the LEVEL switch is turned fully counterclockwise to the AUTO. position).

Unblanking

The positive rectangular pulse appearing at the cathode of V135B during sweep time is applied as an unblanking pulse to the crt. Action of this pulse is discussed under the description of the crt circuit later in this section. It should be noted that, when the HORIZONTAL DISPLAY switch is in the HORIZ. AMP ONLY position, the Sweep-Gating Multivibrator is disabled, and there is no current flowing through V135A or V145A. Therefore, the cathode of V135B is held at $+225$ volts and the crt is continuously unblanked.

CRT CIRCUIT

The crt in the Type RM503 Oscilloscope makes use of an extra set of deflection plates for unblanking during sweep time. One of these plates has a fixed potential of about $+225$ volts on it; the other is tied to the cathode of V135B in the Time-Base Generator. Quiescently, this latter plate is held at a relatively low potential, in the vicinity of $+80$ volts. Therefore, the electron beam in the crt is deflected and absorbed by the $+225$ -volt plate; none of it reaches the screen. During the sweep time, however, the unblanking

pulse from V135B raises the potential of the second plate from +80 volts to about +225 volts. When this happens, both unblanking deflection plates attract the electron beam in the same amount with the net result that the beam is not deflected toward either plate, but passes on through to the crt screen.

The INTENSITY control varies the control grid of the crt from about -20 volts to -150 volts with respect to the cathode. Connections are provided on the rear of the oscilloscope cabinet to couple an ac signal to the control grid to provide intensity modulation of the trace if desired.

CALIBRATOR

The calibrator provides a 500-millivolt square wave and a 5-millivolt square wave for use in calibrating the gain of the Horizontal and Vertical Amplifiers. The two amplitudes are obtained by tapping off at different points in a voltage divider network.

The square wave is produced by the turning off and on of B886. This is accomplished by the combined action of B886, B883, and C883. B886 and B883 are neon tubes which nominally drop about 60 volts when they are conducting. However, if they are not conducting, they require about 80 volts across them to start conduction.

During the time that B886 is turned off, B883 is conducting. This causes C883 to discharge which allows both plates of B883 to move in a positive direction (60 volts apart). When the common connection at the top of the two neon tubes reaches a potential of about +80 volts with respect to ground, B886 conducts. The current through R886 and R887 produces a 0.5-volt drop across them and the voltage at the upper end of B886 is, therefore, about +60.5 volts with respect to ground. Since the upper plate of C883 is now at about +20 volts with respect to ground, the potential across B883 is only about 40 volts, and B883 stops conducting. With no current through B883 to maintain the charge on C883, the upper plate of C883 starts to move in a negative direction. The upper end of B883 is held steady at +60.5 volts by the drop across B886, R886, and R887, so when the upper plate of C883 becomes -20 volts with respect to ground, B883 conducts. This drops the voltage at the upper end of the two neon tubes to +40 volts, and B886 cuts off, completing one cycle of the square wave.

It should be noted that the potentials mentioned in the foregoing discussion (except the drop across R886 and R887) are typical nominals only, and may vary considerably among different units. The only effect will be a slight variation in the frequency and symmetry of the output waveform.

The CAL. ADJ. control, R880, provides a means of adjusting the voltage drop across R886 and R887 by controlling the current through them.

POWER SUPPLY

T601 provides filament power for the graticule lights and all of the tubes, except the first stage of the Input Amplifier, and B+ voltage (about 500 volts) for the power supply oscillator tube, V620. The rest of the voltages used in the oscilloscope are provided by the secondary of T620.

V620, the primary of T620, and part of the secondary of T620 form an Armstrong oscillator circuit to drive T620 at about 25 kc. Each of the outputs of the secondary of T620 bears a fixed turn ratio to the others such that a change in one effects a proportional change in each of the others. Adjustment and regulation of all of the output voltages, then, are accomplished through adjustment and regulation of just one output, the -100 volt output. This, in turn, is referenced to the 85-volt drop across the voltage regulator tube, V659.

Adjustment of the output voltages is accomplished by means of the -100 V ADJ. control as follows. Moving the wiper arm of the -100 V ADJ. control in a positive direction reduces the bias on V635B. This, in turn, lowers the voltage at the plate of V634B and, therefore at the grid of V634A. This causes an increase in voltage at the plate of V634A which, in turn, increases the screen voltage of V620. Increasing the screen voltage of V620 increases the G_m , and therefore the gain, of the tube, and thereby increases the amplitude of oscillations in the secondary of T620. This results in greater output from all of the supplies.

Regulation is accomplished in virtually the same manner. A lowering of the source voltage to which the oscilloscope is connected, or a lowering of any of the output voltages due to loading, causes the volts per turn in the secondary of T620 to decrease. This causes the -100-volt supply to drop (move positively) with the resulting rise in the grid voltage of V634B. This results, as before, in a rise in the screen voltage of V620 and an increase in the amplitude of oscillations, bringing the power supply outputs back to their nominal values.

An increase in any of the output voltages, whatever the reason, has the opposite effect on the screen voltage of V620 and decreases the amplitude of oscillations in T620.

Regulation of the power supply outputs will be accomplished as long as the source voltage remains between 105 and 125 for 117-volt operation, or between 210 volts and 250 volts for 234-volt operation.

SECTION 5

MAINTENANCE

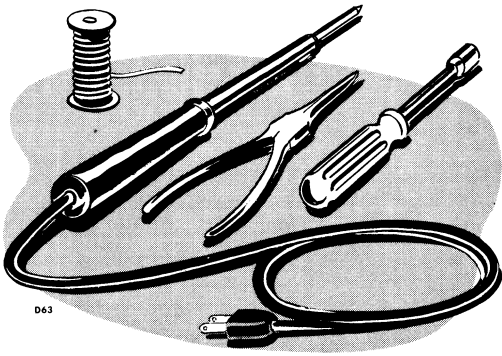

PREVENTIVE MAINTENANCE

Visual Inspection

Every few months, the oscilloscope should be visually inspected so that possible circuit defects may be detected. These defects may include such things as loose or broken connections, damaged binding posts, improperly seated tubes, scorched wires or resistors, missing tube shields, and broken terminal strips. For most visual troubles the remedy is apparent; however, particular care must be taken when heat-damaged components are detected. Overheating of parts is often the result of other, less apparent, defects in the circuit. It is essential to determine the cause of overheating before replacing heat-damaged parts, in order to prevent further damage.

Calibration

The Type RM503 Oscilloscope is a stable instrument which should provide many hours of trouble-free operation. However, to insure the reliability of measurements we suggest that you calibrate the instrument after each 500 hours of operation (or every six months if used intermittently). A complete step-by-step procedure for calibrating the instrument is presented in the Calibration section of this manual.

REMOVAL AND REPLACEMENT OF PARTS

General Information

Procedures required for replacement of most parts in the Type RM503 Oscilloscope are obvious. Detailed instructions for their removal are therefore not required. Other parts, however, can best be removed if a definite procedure is followed. Instructions for the removal of some of these parts are contained in the following paragraphs. Because of the nature of the instrument, replacement of certain parts will require recalibration of sections of the oscilloscope to insure proper operation. Refer to the Calibration section of this manual.

Replacement of the Cathode-Ray Tube

To remove the cathode-ray tube, first disconnect the tube socket and all leads connected to the neck of the tube. Remove the graticule cover, spacer washers, graticule, and graticule light shield. Loosen the tube clamp at the base of the crt. Pull the crt straight out through the front panel.

When the new crt is in place, the leads can be properly connected to the neck of the tube by following the color code information provided on the tube shield. After replacement of the crt, it may be necessary to calibrate certain portions of the oscilloscope. Special attention should be given to calibration of the sweep and the vertical deflection factor.

Replacement of Switches

Methods for removal of defective switches are, for the most part, obvious and only a normal amount of care is required. Single wafers are normally not replaced on the switches used in the Type RM503. If one wafer is defective, the entire switch should be replaced. Switches can be ordered from Tektronix, either wired or unwired, as desired.

Tube Replacement

Care should be taken both in preventive and corrective maintenance that tubes are not replaced unless they are actually causing trouble. Often during routine maintenance it will be necessary to remove tubes from their sockets. It is important that these tubes be returned to their same sockets unless they are actually defective. Unnecessary replacement or switching of tubes will often necessitate calibration of the instrument. If tubes do require replacement, it is recommended that they be replaced by previously checked high-quality tubes.

Soldering Precautions

In the production of Tektronix instruments, a special silver-bearing solder is used to establish a bond to the ceramic terminal strips. This bond can be broken by repeated use of ordinary tin-lead solder, or by the application of too much heat. However, occasional use of ordinary solder will not break the bond if too much heat is not applied.

It is advisable to have a stock of solder containing about 3% silver if you frequently perform work on Tektronix instruments. This type of solder is used frequently in printed circuitry and should be readily available. It may also be purchased directly from Tektronix in one-pound rolls (order by part number 251-514).

Because of the shape of the terminals on the ceramic terminal strips, it is advisable to use a wedge-shaped tip in your soldering iron when installing or removing parts from the strips. A wedge-shaped tip allows you to apply

heat directly to the solder in the terminals and reduce the amount of heat required. It is important to use as little heat as possible.

REPLACEMENT PARTS

Standard Parts

Replacements for all parts used in the Type RM503 Oscilloscope can be purchased directly from Tektronix at current net prices. However, since most of the components are standard electronic parts, they can generally be obtained locally in less time than required to obtain them from the factory. Before ordering or purchasing parts, be sure to consult the parts list to determine the tolerances and ratings required. The parts list gives the values, tolerances, ratings, and Tektronix part number for all components used in the instrument.

Special Parts

In addition to the standard electronic components mentioned in the previous paragraph special parts are also used in the assembly of the Type RM503 Oscilloscope. These parts are manufactured or selected by Tektronix to satisfy particular requirements. Occasionally they are manufactured especially for Tektronix by other companies in accordance with Tektronix specifications. These parts, and most mechanical parts should be ordered directly from Tektronix since they are normally difficult or impossible to obtain from other sources. All parts may be obtained directly from the factory or through the local Tektronix Field Office.

Parts Ordering Information

Each part in the Type RM503 Oscilloscope has a 6-digit Tektronix part number. This number and a description of the part will be found in the parts list. When ordering parts, be sure to include the following information.

1. A description of the part.
2. The part number.
3. The instrument type and serial number.

For example, a certain resistor should be ordered as follows: R143, 22.6 k 1/2 watt, fixed resistor, tolerance 1%, part number 309-136 for a Type RM503 Oscilloscope, serial number_____. When parts are ordered in this manner we are able to fill your orders promptly, and delays that might result from transposed numbers in the part number are avoided.

NOTE

Always include the instrument TYPE and SERIAL NUMBER in any correspondence concerning this instrument.

TROUBLESHOOTING

Troubleshooting Information

The Troubleshooting section is divided into two sections; Circuit isolation and Circuit Troubleshooting. Upon detecting an apparent trouble, you can refer to the Circuit Isolation section to locate the proper circuit to check. After determining which circuit is at fault, you can then refer to the Circuit Troubleshooting information, where the procedure for troubleshooting within the circuit is given. Before attempting to troubleshoot the Type RM503, make sure that any apparent trouble is actually due to a malfunction within the instrument and not due to improper control settings. Operating instructions for the Type RM503 are contained in Section 3 of this manual.

Although the Type RM503 Oscilloscope is a stable instrument, many apparent troubles will be due to improper calibration of one or more circuits. One of the first steps in any troubleshooting procedure should be to check the calibration of the suspected circuit. A complete calibration procedure is given in Section 6 of this manual.

Power-supply output voltages should be checked whenever any type of trouble occurs in the instrument. Due to the circuit configuration employed in the Type RM503, it is possible for an incorrect power-supply voltage to affect one circuit more than others. When all but one circuit in the oscilloscope is functioning properly, there is a tendency to overlook the power supply as a source of the trouble and to concentrate on the circuit where the trouble apparently exists. In cases of this type, valuable time may be saved by checking the power supplies first. If the output and ripple voltages of the regulated power supplies are correct, the power supplies can be assumed to be operating correctly.

When the trouble has been isolated to a definite circuit, perform a complete visual check of that circuit. Many troubles can be found easily by visual means. If a visual check fails to detect the cause of the trouble, check all tubes by substitution. Tube failure is the most prevalent cause of circuit failure. Do not depend on tube testers to adequately indicate the suitability of a tube for use in the instrument. The criterion for usability of a tube is whether or not it works satisfactorily in the instrument. Be sure to return any tubes found to be good to their original socket.

Separate circuit diagrams for each circuit are contained in the Parts List and Schematic Diagrams Section of this manual. In addition, a block diagram provides an overall picture of instrument operation. The reference designation of each electronic component in the instrument is shown on the circuit diagrams, in addition to important voltages and waveforms. The following chart lists the reference designations associated with each circuit.

All numbers less than 100	Sweep Trigger
All 100 numbers	Sweep Generator
All 300 numbers	Horizontal Amplifier and Horizontal Display Switch
All 400 numbers	Vertical Amplifier and Attenuator Switch
All 600 numbers	Power Supply
All 800 numbers	Crt Circuit and Calibrator

Switch wafers shown on the circuit diagrams are coded to indicate the position of the wafer on the actual switches. The number portion of the code refers to the wafer number on the switch assembly. Wafers are numbered from the front of the switch to the rear. The letters F and R indicate whether the front or the rear of the wafer is used to perform the particular switching function.

CIRCUIT ISOLATION

Although the Type RM503 Oscilloscope is a complex instrument, it can be thought of as consisting of six main circuits in addition to the calibrator circuit. These are the:

1. Power Supply
2. Crt Circuit
3. Sweep Generator
4. Sweep Trigger
5. Vertical Amplifier
6. Horizontal Amplifier

The first circuit to check, for practically any type of trouble, is the Power Supply circuit. An improper output voltage from this supply will affect the operation of the entire instrument.

The crt display can often be used to isolate the trouble to one particular circuit when trouble obviously exists in that circuit. If there is no vertical deflection, for example, when the intensity and horizontal deflection appears to be normal, it is apparent that an open condition exists in the Vertical Amplifier and this circuit should be investigated first.

This portion of the troubleshooting procedure lists some of the troubles that can be caused by a circuit failure in the Type RM503 Oscilloscope. It also describes checks that can be made to isolate the faulty circuit or circuits. In some cases simple front panel checks can determine which circuit is defective, but in other cases internal checks and/or measurements are required.

The following troubleshooting information is divided according to the various types of trouble. Upon detecting an apparent trouble, you can use the symptoms to locate the proper circuit to check. After determining which circuit is at fault, you can refer to the Circuit Troubleshooting information, where the procedure for troubleshooting within the circuit is given.

No Spot or Trace

The inability to display a spot or trace on the face of the crt may be due to a defective power supply, an unbalanced condition in either or both of the deflection amplifiers, a defect in the Sweep Generator, or a defective Crt Circuit.

To determine which circuit is at fault, turn the INTENSITY control clockwise. Set the LEVEL control to FREE RUN and the SWEEP TIME/CM control to the 1 mSEC position. Set the HORIZONTAL DISPLAY switch to the SWEEP NORMAL X1 position.

The first section to check for trouble is the Power Supply. If the output voltages of the Power Supplies are correct (see Fig. 6-1), proceed to the next step.

A quick check for correct operation of the Sweep Generator is to turn the HORIZONTAL DISPLAY switch to the HORIZ. AMP ONLY position. Adjust the VERTICAL POSITION and the HORIZONTAL POSITION controls. A spot should appear if the Sweep Generator is defective.

If a spot does not appear with HORIZONTAL DISPLAY switch in the HORIZ. AMP. ONLY position, short the vertical deflection plates together. Be careful not to short either pin to the metal shield around the crt. Adjust the HORIZONTAL POSITION control and see if a spot appears on the crt. If so, a state of unbalance in the vertical deflection system is indicated.

If no spot appeared during the previous check, short the horizontal deflection plates together. Adjust the VERTICAL POSITION control and see if a spot now appears on the screen. If so, a state of unbalance in the horizontal deflection system is indicated.

If neither of the previous checks indicates the source of trouble, check the cathode voltage of V135B; this should be about +225 volts. This voltage is the unblanking potential for the crt and must be applied to the crt to obtain a spot or trace.

If none of the previous checks indicates the source of trouble, a defective crt or trouble in the CRT Circuit is indicated.

Insufficient Vertical Deflection, Waveform Distortion, or Low Differential Input Rejection Ratio

These troubles are all caused by a defective vertical amplifier. Refer to the Circuit Troubleshooting section of the Troubleshooting procedure.

Insufficient or No Horizontal Deflection

Either of these conditions can be produced by the Sweep Generator or the Horizontal Amplifier. If the sweep is shortened but the timing is not affected, the trouble is probably in the Sweep Generator. If both the sweep length and the timing are affected, the trouble is probably in the Horizontal Amplifier.

As an additional check to determine which circuit is defective, place the HORIZONTAL DISPLAY switch in the HORIZ. AMP. ONLY position. Set the HORIZONTAL SENSITIVITY switch to the .1 VOLTS/CM position and the VARIABLE control fully clockwise. Connect the 500mV calibrator signal to the +INPUT connector of the horizontal channel.

Two dots, spaced 5 cm apart, should appear when the positioning controls are adjusted. If the deflection is correct, the trouble is probably in the Sweep circuit. If the deflection is not correct, the trouble is in the Horizontal Amplifier.

Nonlinear Horizontal Sweep

The linearity of the horizontal deflection can be checked by connecting a marker generator or the Calibrator output to a vertical input of the oscilloscope. If the sweep is linear, the markers or the calibrator waveform will be spaced equi-

Maintenance—Type RM503

distant along the sweep. A nonlinear sweep can be caused by either the Sweep Generator or the Horizontal Amplifier.

To determine which circuit is defective, place the HORIZONTAL DISPLAY switch in the HORIZ. AMP. ONLY position. Set the HORIZONTAL SENSITIVITY control to .5 VOLTS/CM position and the VARIABLE control fully clockwise. Connect the 500mV signal from the CAL. OUT connector to the +INPUT connector of the Horizontal Channel.

Two dots, spaced 1 cm apart, should appear when the positioning controls are adjusted. If the spacing between dots remains the same as they are moved across the screen with the HORIZONTAL POSITION control the nonlinearity is probably in the Sweep Generator. If the spacing between dots varies, the trouble is in the Horizontal Amplifier.

Improper Sweep Timing

If the timing is off in some, but not all, positions of the SWEEP TIME/CM switch, one of the timing resistors or timing capacitors has changed in value. By comparing the switch positions in which the timing is incorrect with the Timing Switch diagram, you will be able to tell which components are common to these positions.

If the timing is off in all positions of the SWEEP TIME/CM switch, the Horizontal Amplifier is probably the circuit at fault. However, it is important that the power supply voltages be checked. Check to see if the timing circuits can be calibrated in accordance with the instructions presented in the Calibration section of this manual. If the circuits cannot be adjusted for correct timing, then refer to the section on troubleshooting the Horizontal Amplifier.

Improper Triggering

If the waveform you are observing cannot be triggered (locked into position) properly, the trouble can be misadjustment of the STABILITY control or malfunction of some other part of the Sweep circuit or the Trigger circuit.

Check the adjustment of the STABILITY control as described in the Calibration section of this manual. If the trace can be turned on and off by rotating the LEVEL control into and out of the FREE RUN position, the Trigger circuit is probably causing the trouble. If the trace cannot be turned off with the LEVEL control, the Sweep circuit is likely at fault.

CIRCUIT TROUBLESHOOTING

This portion of the Troubleshooting procedure contains information for locating a defective stage within a given circuit. Once the stage at fault is known, the component or components causing the trouble can be located by tube and component substitution, voltage and resistance measurements, or by short and continuity checks.

As mentioned previously, tube failure is the most prevalent cause of circuit failure. For this reason, the first step in troubleshooting any circuit is to check for defective tubes, preferably by direct substitution. Be sure to return any tubes found to be good to their original sockets.

If replacement of a defective tube does not correct the trouble, then check to see that components through which the tube draws current have not been damaged. Shorted tubes will often overload and damage plate load and cathode resistors. These components can sometimes be located by a visual inspection of the circuit. If no damaged components are apparent, however, it will be necessary to make measurements or other checks within the circuit to locate the trouble.

Troubleshooting the Power Supply

Proper operation of every circuit in the Type RM503 Oscilloscope depends on proper operation of the Power Supply. The voltages must remain within their specified tolerances for the instrument to maintain its calibration.

No output voltage. If the graticule lamps do not operate when the POWER switch is turned on, check the POWER switch, the fuse and the line voltage. Shorts in the primary and secondary circuits of T601 will cause the fuse to blow. If the fuse is not blown and the line voltage is correct, next check the primary windings of the power transformer.

If the graticule lamps operate correctly, the primary circuit of the power transformer (T601) is operating normally and the trouble lies somewhere in the secondary circuit or the oscillator circuit (V620, T620).

To check the secondary circuit of T601, measure the voltage at the junction of D612 and C612 (Fig. 6-1). This voltage should be approximately +500 volts. Check the secondary winding of T601 and the voltage doubler circuit if the voltage is not correct. A reading of approximately 600 volts or more at the junction of D612 and C612 indicates the oscillator circuit (V620, T620) is inoperative. Before replacing V620, check for defective parts associated with V620. Some of the parts to check, for example, are T620, C620, C621, and R621.

If the proper output voltage is obtained from at least one of the power supplies, the oscillator circuit need not be checked. In this case, you should check the rectifier and components associated with the inoperative supply.

Failure to regulate at the correct voltage. If the supplies fail to regulate at the proper voltages, first check the line voltage. The supplies are designed to regulate between an input voltage of 105 and 125 volts (or 210 and 250 volts), with the design center at 117 volts (or 234 volts), rms. Improper line voltage may cause the supply voltages to be off.

If the output of any of the supplies is off by only a small amount, it may be possible to readjust the -100 ADJ. control to obtain the proper voltage. It should be noted that when the setting of the -100 ADJ. control is changed, the entire instrument must be recalibrated according to the procedure given in Section 6 of this manual.

If the supplies fail to regulate, check the tubes (if this has not already been done). Then make sure that the voltage at the junction of D612 and C612 is approximately +500 volts. Check for off-value resistors, especially in the dividers, and for open or leaky capacitors associated with V634.

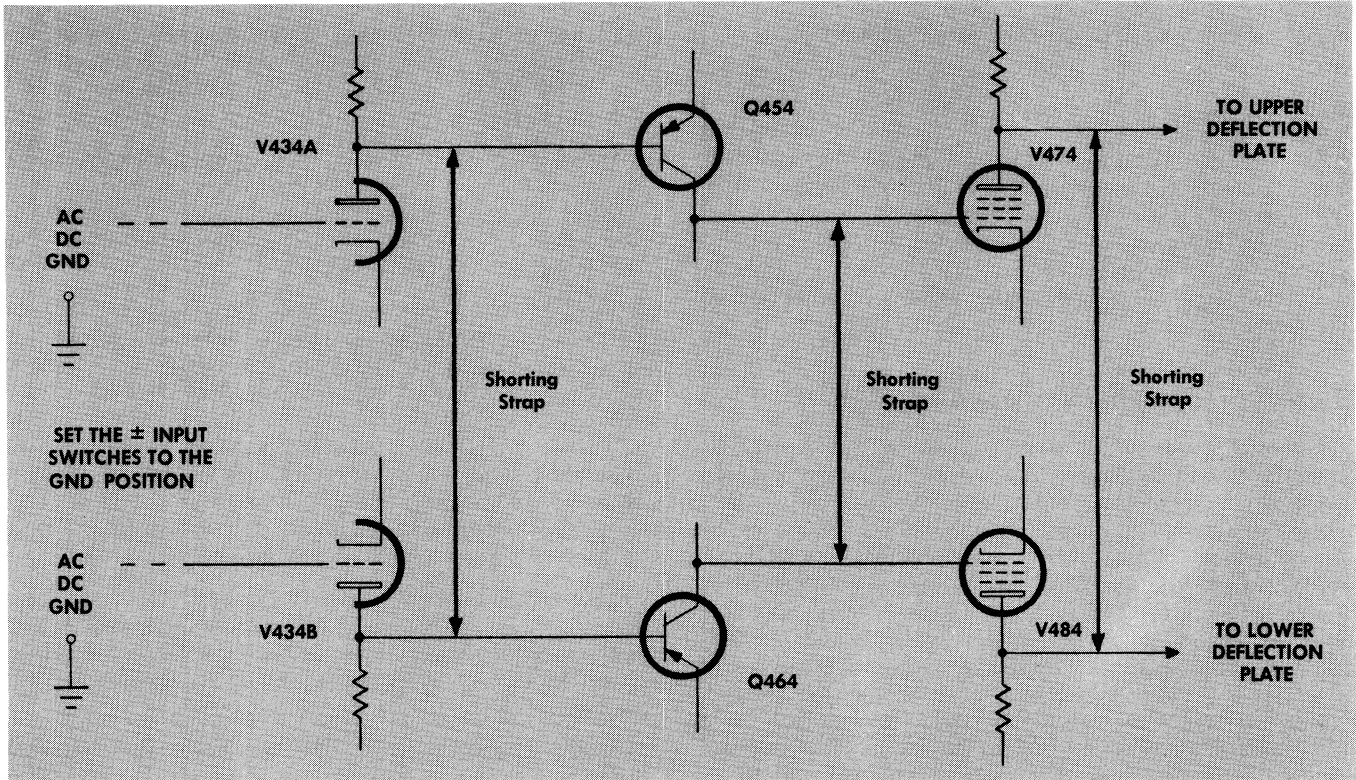

Fig. 5-1. Checking the Vertical Amplifier for an unbalance condition.

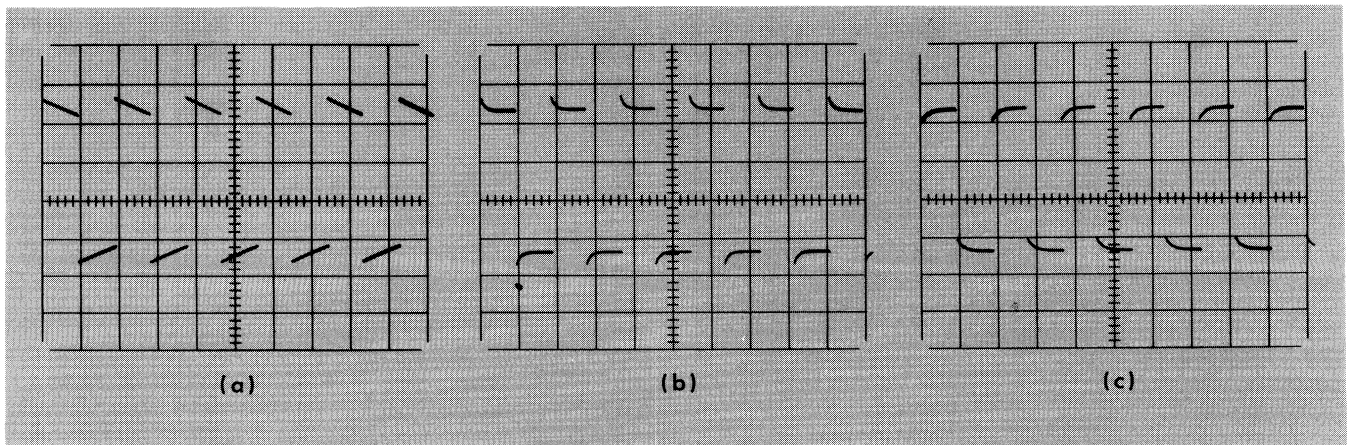

Fig. 5-2. Frequency distortion. (a) Low-frequency distortion of an ac-coupled 100-cps square wave due to attenuation of the low-frequency components of the waveform. (b) High-frequency distortion of a 1000-cps square wave due to excessive boost of the high-frequency components of the waveform. (c) High-frequency distortion of a 1000-cps wave due to attenuation of the high-frequency components of the waveform.

Maintenance—Type RM503

If there is excessive ripple on only one of the supplies, check for open or leaky capacitors in that circuit.

Troubleshooting the CRT Circuit

Trouble other than power supply trouble which affects the CRT Circuit will generally be caused by defects in the intensity and focus voltage dividers, defects in the divider associated with pins 7 and 11 of the crt, by the astigmatism control, or by the crt itself. These parts (except for the crt) can be checked by voltage and resistance measurements. If the circuits check out satisfactorily replace the crt.

Troubleshooting the Vertical Amplifier

No spot or trace. As mentioned earlier in the troubleshooting procedure, if a spot is visible when the vertical plates are externally shorted together, but disappears when the short is removed, the Vertical Amplifier is in a state of dc unbalance. To locate the defective stage, first set both INPUT switches to the GND position and the SENSITIVITY switch to the .2 VOLTS/CM position. Then, with an insulated shorting strap, short between the points shown in Fig. 5-1, starting at the right and progressing toward the left. As you short between the points, in turn, the spot should appear on the screen as each connection is made. You may have to readjust the POSITION control when shorting between plates of the input stage. With the input stage grounded, the DC BAL. control may have to be readjusted.

When you reach a point where the spot does not return to the screen, the stage immediately following this point is at fault. The trouble may be caused by a defective tube, transistor, resistor, capacitor, or broken lead.

Insufficient or no vertical deflection. Insufficient vertical deflection indicates a change in the gain characteristics of the Vertical Amplifier. If the change in gain is small, the Vertical Amplifier can usually be calibrated for gain. In this event, refer to the Calibration section of this manual.

If the change in gain is more pronounced, or if there is no vertical deflection at all, the tubes and transistors should first be checked. Then check for components which can affect the gain of the circuit but not the dc balance. Such parts are common cathode resistors in the Input and Output Amplifier stages, or plate dropping resistors which are common to both sides of the amplifier.

Insufficient vertical deflection will also be caused if the frequency limits of the amplifier are exceeded.

Waveform distortion. Waveform distortion can be divided into two categories—low frequency and high frequency. If a square wave is applied to an input of the oscilloscope, the type of distortion can be determined by the shape of the displayed waveform. High frequency distortion will primarily affect the leading edge and trailing edge of the applied square wave while low frequency distortion will primarily affect the midportion of the waveform.

Waveforms showing low frequency distortion and two types of high frequency distortion are shown in Fig. 5-2. The shape of these waveforms will vary widely, however, with the cause of the distortion and the frequency of the applied waveform. A nominal amount of low frequency distortion is normal for very low input frequencies when ac

coupling is used, and a nominal amount of high frequency distortion is normal at the upper frequency limits of the instrument. It is only when this distortion is excessive in the normal frequency range of the instrument that it constitutes a trouble.

Low frequency distortion is usually caused by a change in the time constant of the input coupling circuit. If tubes become gassy, however, their resultant grid current will establish a time constant network which will affect the low frequency response of the circuit.

Factors which can affect the high frequency response of the vertical amplifier are mainly related to the high frequency compensation networks. An overshoot waveform can be caused by excessive high-frequency peaking or by a tube condition known as cathode interface. If this type of distortion is detected, check the tubes in the amplifier. If tube replacement does not completely correct the trouble, then check the adjustment of C406 and C416 and the high frequency compensation networks in the attenuators. Refer to the Calibration section of this manual.

Undershoot or rolloff can be caused by insufficient high-frequency peaking and by tubes. If tube replacement does not correct this type of distortion, then check the adjustments of C406 and C416 and the divider networks in the attenuators.

Low differential input rejection ratio. Low rejection ratio is usually caused by tubes or transistors. If replacement of tubes or transistors does not correct the trouble, then check for components which can affect the balance of the circuit.

Troubleshooting the Horizontal Amplifier

If a spot is visible when the horizontal deflection plates are externally shorted together, but disappears when the short is removed, the Horizontal Amplifier is in a state of unbalance.

When the HORIZONTAL DISPLAY switch is in the HORIZ. AMP ONLY position, the operation of the Horizontal Amplifier is virtually identical to that of the Vertical Amplifier. Therefore, the procedure for troubleshooting the Horizontal Amplifier is the same as that explained previously for troubleshooting the Vertical Amplifier.

Troubleshooting the Sweep Trigger Circuit

To determine which stage is defective, rotate the TRIGGER LEVEL control fully counterclockwise to the AUTO. position. With no triggering signal, the sweep should appear on the crt. If the sweep does not appear, either the Trigger Multivibrator is defective or the STABILITY ADJUST is misadjusted. Refer to the Calibration section for adjustment procedures for the STABILITY ADJUST. If the sweep does appear, either the Trigger Amplifier or the Trigger Multivibrator may be at fault.

A check on the Trigger Amplifier circuit may be made as follows. With the LEVEL control still in the AUTO. position, measure the voltage at the plate, pin 6, of V24B. This voltage should be approximately +98 volts. If the voltage is incorrect, the trigger amplifier circuit is defective. The

trouble will probably exist in the tube, resistors, or switches of the circuit.

If the voltage measured at pin 6 of V24B is correct, rotate the LEVEL control completely through its range while monitoring the voltage at this point. The voltage should vary between approximately 70 and 130 volts. An incorrect voltage range indicates a defective amplifier or LEVEL control. If the voltage range is correct, the trouble is in the trigger multivibrator. A trouble in the multivibrator will probably be due to a defective tube or resistor. The voltage divider network between the plate of V45A and the grid of V45B is particularly critical.

Troubleshooting the Sweep Generator Circuit

It is important that you understand the operation of the Sweep Generator circuit before proceeding with any extensive investigation of the circuit. For this reason, we suggest that you thoroughly study that portion of the Circuit Description that pertains to this circuit.

No horizontal sweep. If the sweep circuit is not producing a sawtooth waveform when the TRIGGER LEVEL control is in the FREE RUN position, some defect in the circuit is causing the output to remain at some fixed voltage. A clue to the cause of this trouble can be obtained by measuring the plate voltage of the Miller tube, V160A.

NOTE

All voltages in this section should be measured with a 20,000 ohms-per-volt voltmeter or a vacuum-tube voltmeter.

The voltage reading obtained will probably be approximately +200 volts, or approximately +30 volts. A reading of +200 volts indicates that the Miller stage has run up and has not been reset, while a reading of +30 volts indicates that the Miller stage is not being allowed to run up. The condition that actually exists will depend on the type of trouble occurring in the circuit. The two conditions of the plate voltage will be handled separately in the following paragraphs.

High voltage at the plate of the Miller tube, V160A, indicates the tube is cut off. This can result from any one of the following conditions: (1) The Disconnect Diodes do not conduct, (2) Sweep-Gating Multivibrator does not reset, (3) Hold off Circuit does not reset the Sweep-Gating Multivibrator and, (4) Runup Cathode Follower does not drive the Hold-Off Circuit. The defective stage can be detected by a series of systematic voltage measurements. When an improper voltage reading is obtained, this will indicate the defective stage.

Check the voltage at the grid of the Miller tube, pin 2, V160A. The static voltage at the Miller grid is determined by conduction through the Timing Resistor, R160 (from -100 volt bus), the lower diode, V152B, and resistor R147. If the voltage reading is less than -4 volts, V152B is probably conducting normally and can be eliminated as a possible cause of the trouble. If the voltage is more negative than approximately -20 volts, the diode is probably not conducting. Check V152 and resistor R147.

Measure the voltage at the output of the Sweep Generator circuit (pin 8 of V160B). If this voltage is approxi-

mately +150 volts, the Runup Cathode Follower stage may be assumed to be operating correctly. If this voltage is low, however, the stage is defective and its grid and cathode circuits should be checked.

Next, measure the voltage at the cathode of V145B, pin 3. If this voltage is more positive than -55 volts the trouble is in the Sweep-Gating Multivibrator. Check the tubes and resistors in this circuit. The voltage divider network in the cathode of V135B is particularly critical.

If the voltage at the cathode of V145B, pin 3, is more negative than -55 volts, check the tubes in the Hold-Off Circuit, the Hold-Off capacitor, and resistors in the cathode circuit of the two tubes.

Low voltage at the plate of the Miller tube indicates that the tube is conducting quite heavily and is not being allowed to perform its normal runup operation. If this trouble exists on only a few ranges of the SWEEP TIME/CM switch, the trouble is likely to be an open timing resistor. If the trouble exists on all ranges of the SWEEP TIME/CM switch, the trouble is probably due to a defective Sweep-Gating Multivibrator.

To check the Sweep-Gating Multivibrator, monitor the voltage at pin 3 of V145B and adjust the STABILITY ADJUST control for a reading of -66 volts on the voltmeter. With this voltage, the Sweep-Gating Multivibrator and the sweep should free run. If the multivibrator does not free run, check the resistances in the stage.

If the voltage at pin 3 of V145B remains relatively constant as the STABILITY ADJUST control is rotated, a defect in the Hold-Off Circuit is indicated. A probable cause of this condition could be a shorted hold-off capacitor. If the voltage does not adjust to the proper level, check the resistors in the cathode circuit of V145B.

Nonlinear sweep. A nonlinear sweep voltage will be generated if the current charging the Timing Capacitor does not remain constant. If the nonlinearity exists at all sweep rates, a defective Miller tube (V160A) is the probable cause of the trouble. If the nonlinearity occurs only at certain rates, a faulty Miller tube or a leaky Timing Capacitor is the probable cause.

Insufficient horizontal deflection. If the horizontal trace starts at the left-hand side of the screen, but does not extend to the right-hand side, the Hold-Off Circuit is resetting the Sweep-Gating Multivibrator before the sweep is complete. If the sweep cannot be adjusted to normal length with the SWP. LENGTH control, R176, the resistance in the cathode circuit of V160B should be checked.

Improper triggering. If the sweep cannot be triggered properly, the gating pulse from the Multivibrator is not turning the Disconnect Diodes (V152A & B) off and on properly. The start of the gating pulse, which turns the diodes off and starts the sweep, is initiated by the triggering pulse at the grid of V135A. The end of the gating pulse, which turns the diodes on and initiates the retrace, is controlled by the hold-off waveform at the grid of V135A. The main component to check, in addition to the tubes, is the differentiating capacitor C131. Misadjustment of the STABILITY ADJUST control (R111) will also cause the Sweep Generator to trigger improperly. Refer to the Calibration section for correct adjustment.

SECTION 6

CALIBRATION

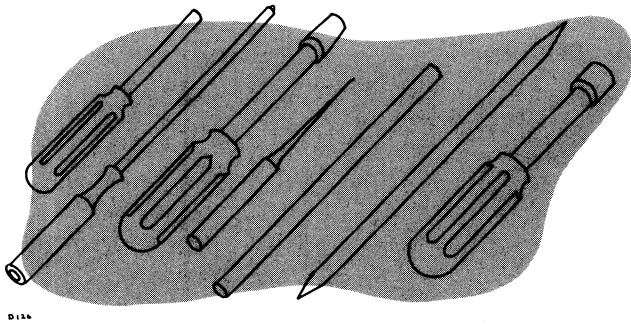

INTRODUCTION

The Type RM503 Oscilloscope is a stable instrument and should not require frequent calibration. However, it will be necessary to calibrate certain parts of the instrument when tubes or components are changed. Also, a periodic calibration is desirable from the standpoint of preventive maintenance.

Apparent trouble in the instrument may be due to improper calibration of one or more circuits. Consequently this section of the manual should be used in conjunction with the Maintenance section during troubleshooting work. If trouble occurs in the instrument, you must be sure that it is not due to improper calibration before proceeding with more detailed troubleshooting.

In the instructions that follow, the steps are arranged in the proper sequence for a complete calibration of the instrument. Each numbered step contains the information required to make one adjustment or a series of related adjustments. Controls not mentioned in a given step are assumed to be set at the positions they were last in during the preceding step.

If a single control requires adjustment, and the particular control is known, it can often be adjusted without calibrating the entire instrument, provided the control does not interact with other adjustments. In such cases, the control is adjusted in the normal manner, as described in the applicable calibration step. It may be necessary, however, for you to refer to the calibration steps immediately preceding the adjustment you wish to make to determine the proper setting for the controls not mentioned in that step. Due to the interaction between adjustments in the horizontal and vertical amplifiers, single adjustments in these circuits usually cannot be made. When amplifier adjustments are required, the entire amplifier should be calibrated. In addition, if the -100-volt supply is adjusted, the entire instrument must be calibrated.

Fig. 6-6 and Fig. 6-7 show the location of the internal adjustments referred to in the calibration procedure.

EQUIPMENT REQUIRED

The following equipment is necessary for a complete calibration of the Type RM503 Oscilloscope.

1. DC voltmeter (sensitivity of at least $5000 \Omega/v$), calibrated for an accuracy of 1% at 12.6, 85, 100 and 250 volts, and for an accuracy of 3% at 3000 volts.
2. Accurate rms-reading ac voltmeter, having a range of at least 0-125 volts. (0-250 for 234-volt operation.)

3. Variable autotransformer having a rating of at least 500 watts.

4. Time-Mark Generator, Tektronix Type 180 or Type 180A or equivalent. Time-mark generator used must have markers at $1 \mu\text{sec}$, $10 \mu\text{sec}$, 1 msec, 5 msec, 10 msec, 100 msec, 1 sec, and 5 sec, with an accuracy of at least 1%.

5. Square-Wave Generator, Tektronix Type 105 or equivalent. Required specifications are: (1) output frequency of approximately 1 kilocycle, (2) risetime of 0.02 microsecond or less, and (3) output amplitude variable from about 40 millivolts to 100 volts.

6. For all Type RM503 Oscilloscopes S/N 136 and up, constant amplitude Sine-wave Generator having outputs of 50 kc, 350 kc and 450 kc. Tektronix Type 190-series or equivalent.

7. Test oscilloscope with calibrated vertical deflection factors from .01 to 10 volts per division.

8. Low-capacitance calibration tool: Tektronix part number 003-000 or equivalent.

9. Coaxial Cable suitable for applying the outputs of the square-wave generator and the time-mark generator to the inputs of the Type RM503.

10. $47 \mu\text{mf}$ Input Capacitance Standardizer, Tektronix Type CS47 or equivalent.

11. 50Ω Termination (011-045).

12. 50Ω 5:1 Attenuator 5XT (001-032).

ADJUSTMENT PROCEDURE

Preliminary

Remove RM503 from rack remove top and bottom cover, and connect to power source. Set the front panel controls as follows (controls not listed may be left in any position):

SLOPE	+
COUPLING	AC
SOURCE	INT.
LEVEL	ccw but not AUTO.
SWEEP TIME/CM	1 mSEC
VARIABLE	CALIBRATED (fully cw)
INTENSITY	Fully ccw
HORIZONTAL DISPLAY	SWEEP NORMAL (X1)
VERTICAL	
SENSITIVITY	.1 VOLTS/CM
VARIABLE	CALIBRATED (fully cw)
POSITION	midrange
+INPUT	DC
-INPUT	GND

Calibration—Type RM503

Connect the Type RM503 Oscilloscope to the autotransformer, and turn on all equipment. Set the output of the autotransformer to the design center voltage for which your instrument is wired (117 or 234 volts). Allow the instrument to warm up for at least 5 minutes before proceeding with the calibration adjustments.

Power Supply

1. -100 ADJ. With the dc voltmeter measure the output voltage of the -100-, +12.6-, +100-, +250-, and -3000-volt supplies at the points indicated in Fig. 6-1. Set the -100 ADJ. control so that the -100-volt supply is within 2% and the other supplies within 5% of their rated values.

NOTE

Do not adjust the -100 ADJ. control unless one or more of the supplies is actually out of tolerance or unless you are planning to perform a complete recalibration of the instrument.

2. REGULATION. Vary the autotransformer output voltage between 105 and 125 volts (or between 210 and 250 volts if the power transformer is wired for 234-volt operation). All of the regulated voltages should remain within tolerance over this range.

3. RIPPLE. Using the test oscilloscope, check the 120-cycle ripple voltage at the output of each power supply when the output voltage of the autotransformer is set for 117 volts (or 234 volts). Ripple at the output of all of the power supplies, except the -3000-volt supply, should be 25 millivolts or less. Do not attempt to measure the ripple on the -3000-volt supply.

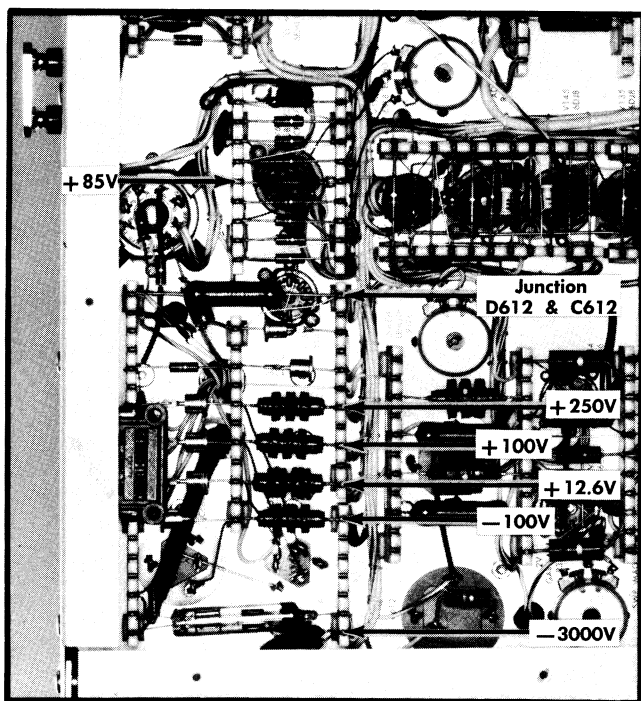

Fig. 6-1. Location of Power Supply test points.

Calibrator

4. CAL. ADJ. Connect the input of the test oscilloscope to the CAL. OUT 500 mV terminal on the front panel. Adjust the CAL. ADJ. control (R880) for an output amplitude of 500 millivolts. Disconnect the test oscilloscope.

CRT Circuit

5. CRT ALIGNMENT. Check to see that the crt rests snugly against the graticule. If it does not, loosen the crt clamp (see Fig. 6-6) and push the tube forward by pushing on the tube socket. Then tighten the crt clamp.

Set the LEVEL control to the FREE RUN position. Turn up the INTENSITY control until a trace is visible (it may be necessary to adjust the VERTICAL POSITION control) and adjust the FOCUS and ASTIGMATISM controls for the narrowest trace width. With the VERTICAL POSITION control, position the trace directly behind the center graticule line. If the trace is tipped relative to the graticule line, rotate the crt alignment knob until the trace coincides with the graticule line.

6. ASTIGMATISM ADJUST. Rotate the FOCUS control fully clockwise and set the HORIZONTAL DISPLAY switch to the HORIZ. AMP. ONLY position. Position the spot onto the screen, and adjust the ASTIG. ADJ. control so that the defocused spot is as nearly circular as possible. Adjust the FOCUS control so that the spot is in sharp focus. The INTENSITY control may have to be adjusted to produce a defocused circle, but care should be taken not to burn the crt face when a sharply focused spot is produced.

Triggering Circuit

7. STABILITY ADJUST*. Set the VERTICAL SENSITIVITY control to the .1 VOLTS/CM position and the HORIZONTAL DISPLAY switch to the SWEEP NORMAL position. Set the LEVEL control to the FREE RUN position and center the trace vertically on the screen. Adjust the INTENSITY and FOCUS controls for best definition. Reset the LEVEL control to AUTO. (full left). Set the STABILITY ADJUST control (R111, Screwdriver adjustment, front panel) fully counterclockwise. Next, turn the STABILITY ADJUST control clockwise until a trace is visible on the crt. Note the position of the control. Then, advance the control further clockwise until the trace brightens. Back off the control and set it midway between the point where the trace first becomes visible and the point where it brightens.

*Although this control is shown on the Sweep Generator circuit diagram, it is more closely associated with the triggering circuitry and its adjustment is therefore included in this section.

Vertical Amplifier

8. COARSE DC BAL. Rotate the LEVEL control to the FREE RUN position. Set the SENSITIVITY control to .2 VOLTS/CM and the VARIABLE control to the CALIBRATED position. Set the DC BAL. control to midrange. Set both VERTICAL INPUT switches to the GND position. Center the trace vertically on the crt with the POSITION CONTROL. Adjust the COARSE DC BAL. control (R436) so that the trace does not shift vertically as the SENSITIVITY switch is rotated between the .2 VOLTS/CM and the 1mV/CM positions.

9. .2V GAIN ADJ. This adjustment and the following step determine the gain of the Vertical Amplifier and therefore the calibration of the SENSITIVITY switch. To adjust the .2V GAIN ADJ. (R478), set the front-panel controls as follows:

SLOPE	+
COUPLING	AC
SOURCE	INT.
LEVEL	AUTO
SWEEP TIME/CM	1 mSEC
VARIABLE	CALIBRATED
HORIZONTAL DISPLAY	SWEEP NORMAL (X1)
VERTICAL	
SENSITIVITY	.1 VOLTS/CM
VARIABLE	CALIBRATED
+INPUT	DC
-INPUT	GND

Connect a jumper wire from the CAL. OUT 500mV connector to the +INPUT connector. Adjust the FOCUS, INTENSITY, and POSITION controls for a suitable display. Adjust the .2V GAIN ADJ. control for a deflection of five centimeters.

10. 1mV GAIN ADJ. Connect the jumper wire from the CAL. OUT 5 mV connector to the +INPUT connector. Set the SENSITIVITY switch to 1 mV/CM. Make sure the SENSITIVITY VARIABLE control has not been moved from

the CALIBRATED position. You may have to adjust the DC BAL. control to position the display on the screen. Adjust the 1 mV GAIN ADJ. control (R460) for five centimeters of vertical deflection. Repeat steps 9 and 10 until both adjustments are correct. Disconnect the jumper wire.

11. HIGH-FREQUENCY COMPENSATION. To adjust the high-frequency compensation of the attenuators, set the front-panel controls as follows:

SLOPE	+
COUPLING	AC
SOURCE	INT.
LEVEL	AUTO.
SWEEP TIME/CM	.5 mSEC
VARIABLE	CALIBRATED
HORIZONTAL DISPLAY	SWEEP NORMAL (X1)
VERTICAL	
SENSITIVITY	.2 VOLTS/CM
VARIABLE	CALIBRATED
+INPUT	DC
-INPUT	GND.

Connect the output of the square-wave generator through the 47- $\mu\mu\text{f}$ capacitance standardizer to the +INPUT connector of the Type RM503. Adjust the square-wave generator for an output frequency of 1 kc. Fig. 6-2 shows the Tektronix Type 105 Square-Wave Generator connected for this step.

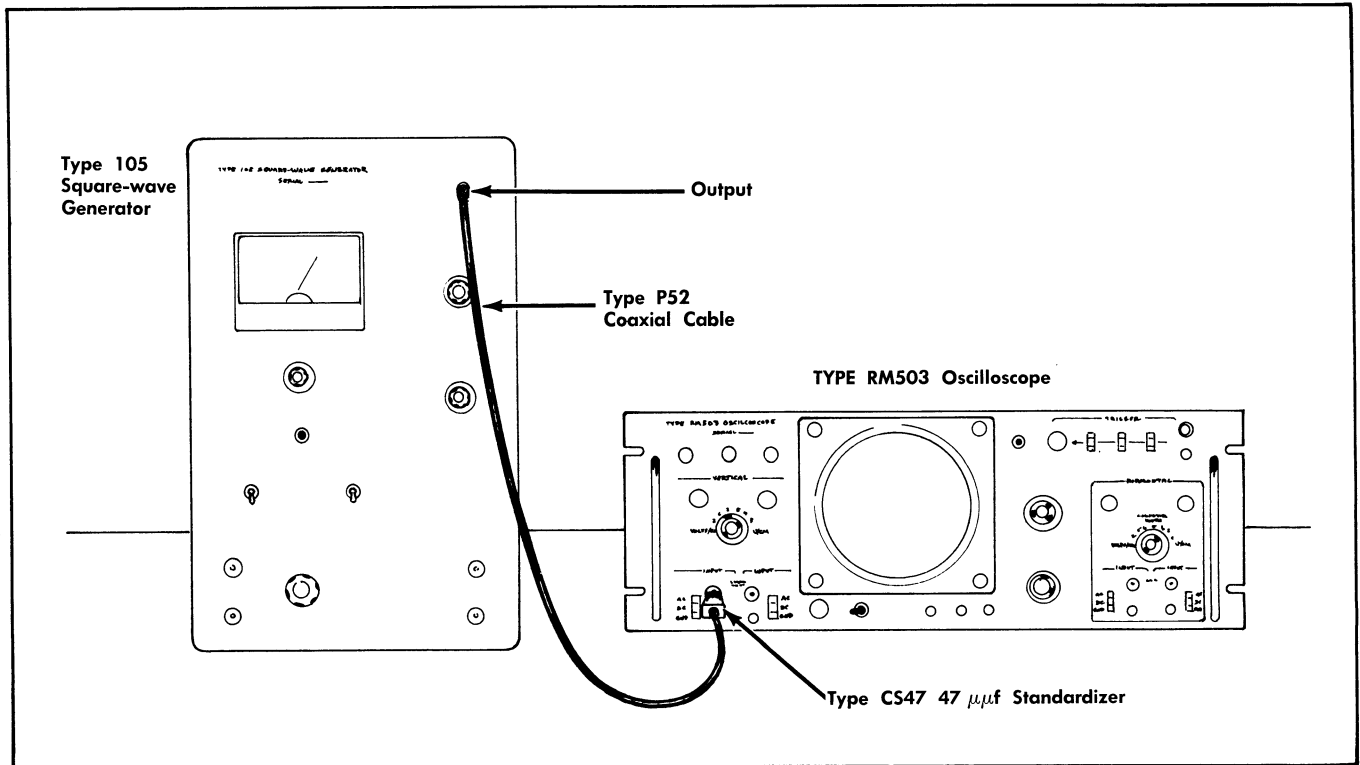

Fig. 6-2. Tektronix Type 105 Square-Wave Generator connected for high-frequency compensation of the Type RM503 Oscilloscope Vertical Amplifier.

Calibration—Type RM503

Set the SENSITIVITY control to the positions indicated in Table 6-1 and adjust the corresponding capacitors for the best square-wave response. C416, C415B, and C414B affect the overall level of the square wave; C415C and C414C have the most effect on a small portion of the leading edge and corner. Maintain about four centimeters of vertical deflection by adjusting the output amplitude of the square-wave generator as you switch the SENSITIVITY control from one setting to the next.

TABLE 6-1

SENSITIVITY	ADJUST
.2 VOLTS/CM	C416
.5 VOLTS/CM	C415B, C415C
5 VOLTS/CM	C414B, C414C

Connect the output of the square-wave generator through the 47- $\mu\mu\text{f}$ capacitance standardizer to the -INPUT connector. Set the -INPUT switch to the DC position and the +INPUT switch to the GND position.

Set the SENSITIVITY control to the positions indicated in Table 6-2 and adjust the corresponding capacitors for the best square-wave response.

TABLE 6-2

SENSITIVITY	ADJUST
.2 VOLTS/CM	C406
.5 VOLTS/CM	C405B, C405C
5 VOLTS/CM	C404B, C404C

Disconnect the 47 $\mu\mu\text{f}$ capacitance standardizer from the -INPUT connector.

Horizontal Amplifier

12. COARSE DC BAL. Set the HORIZONTAL DISPLAY switch to the HORIZ. AMP. ONLY position. Set the HORIZONTAL SENSITIVITY control to .2 VOLTS/CM and the VARIABLE control to the CALIBRATED position. Set the DC BAL. control to midrange. Set both INPUT switches to the GND position. Center the spot horizontally on the crt with the HORIZONTAL POSITION control. Adjust the COARSE DC BAL. control (R346) so that the spot does not shift horizontally as the SENSITIVITY switch is rotated between the .2 VOLTS/CM and the 1mV/CM positions.

13. .2V GAIN ADJ. This adjustment and the following step determine the gain of the Horizontal Amplifier and therefore the calibration of the SENSITIVITY switch. To adjust the .2V ADJ. (R378), set the front-panel controls as follows:

HORIZONTAL DISPLAY	HORIZ. AMP. ONLY
HORIZONTAL SENSITIVITY	.1 VOLTS/CM
VARIABLE	CALIBRATED
+INPUT	DC
-INPUT	GND

Connect a jumper wire from the CAL. OUT 500mV connector to the +INPUT connector. Two dots, spaced approximately five centimeters apart, should appear on the

screen. Adjust the FOCUS, INTENSITY, and POSITION controls for a suitable display. Adjust the .2V GAIN ADJ. control for a deflection of exactly five centimeters.

14. 1mV GAIN ADJ. Connect the jumper wire from the CAL. OUT 5mV connector to the +INPUT connector. Set the SENSITIVITY switch to 1mV/CM. Make sure the SENSITIVITY VARIABLE control has not moved from the CALIBRATED position. You may have to adjust the DC BAL. control to position the signal on the screen. Adjust the 1mV GAIN ADJ. control (R360) for five centimeters of horizontal deflection. Repeat steps 13 and 14 until both adjustments are correct. Disconnect the jumper wire.

15. HIGH-FREQUENCY COMPENSATION. To adjust the high-frequency compensation of the horizontal attenuators, a vertical trace must be obtained by connecting the output of the Sweep Generator to the Vertical Amplifier. To do this, connect the bottom of R144 to an internal source of -100 volts and connect pin 8 of V160 to the +INPUT connector of the Vertical Amplifier. Fig. 6-3 illustrates how these connections can be made. Set the front panel controls as follows:

SLOPE	+
COUPLING	AC
SOURCE	EXT.
LEVEL	AUTO.
SWEEP TIME/CM	1 mSEC
VARIABLE	CALIBRATED
HORIZONTAL DISPLAY	HORIZ. AMP. ONLY
HORIZONTAL SENSITIVITY	.2 VOLTS/CM
VARIABLE	CALIBRATED
+INPUT	DC
-INPUT	GND

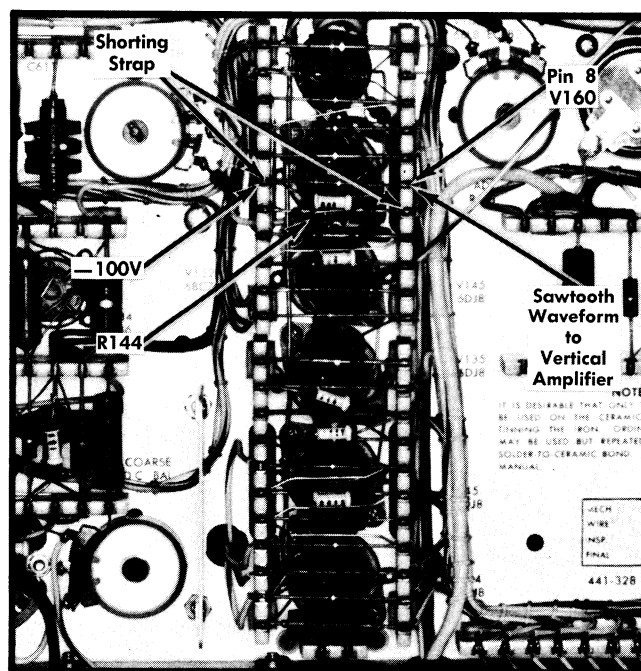

Fig. 6-3. Connections for obtaining a vertical trace on the Type RM503 Oscilloscope.

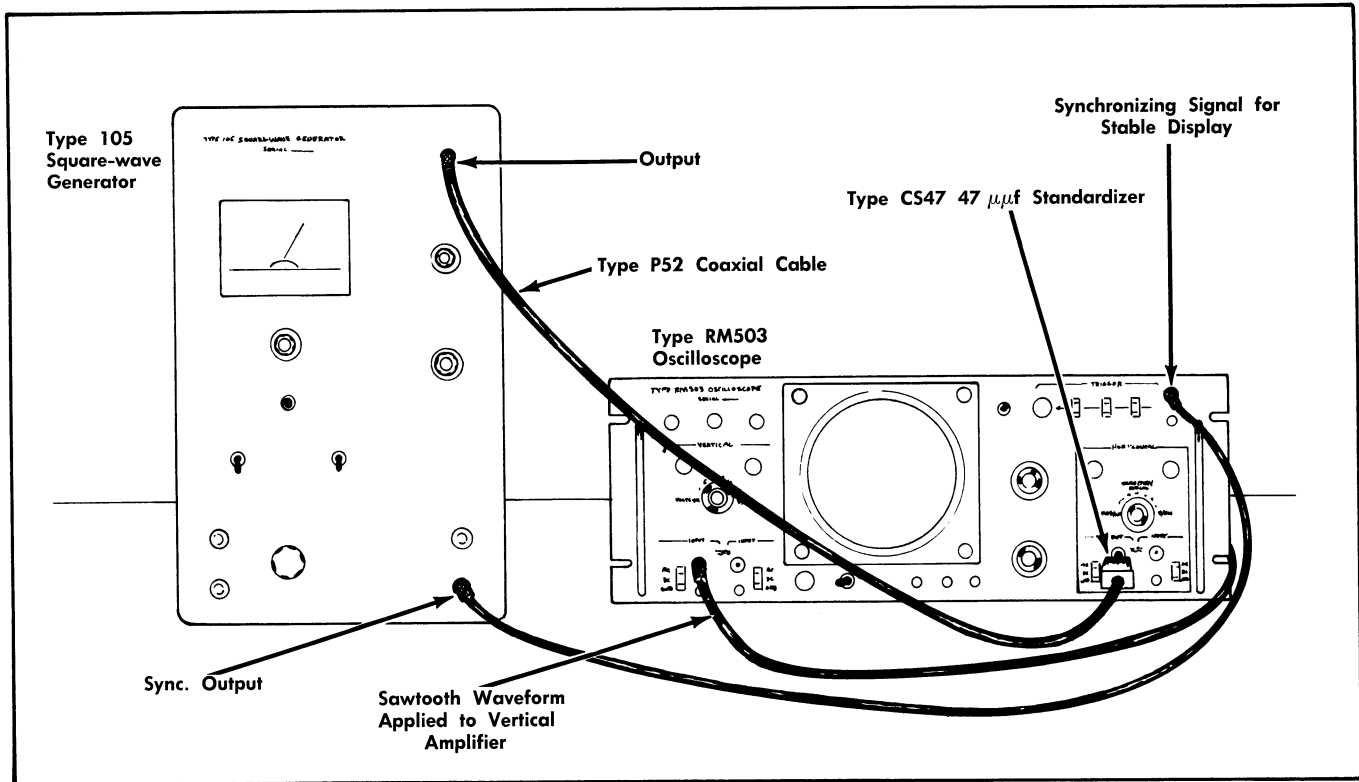

Fig. 6-4. Tektronix Type 105 Square-Wave Generator connected for high-frequency compensation of the Type RM503 Oscilloscope Horizontal Amplifier.

Connect the output of the square-wave generator through the 47- $\mu\mu\text{f}$ capacitance standardizer to the HORIZONTAL +INPUT connector of the Type RM503. Connect a synchronizing output signal from the square-wave generator to the EXTERNAL TRIG. IN connector of the Type RM503. Adjust the square-wave generator for an output frequency of 1 kc. Fig. 6-4 shows the Tektronix Type 105 Square-Wave Generator connected for this step.

Adjust the FOCUS, INTENSITY, and POSITION controls for a suitable display. The display should be similar to Fig. 6-5. Set the SENSITIVITY control to the positions indicated in Table 6-3 and adjust the corresponding capacitors for the best square-wave response. Maintain about four centimeters of horizontal deflection by adjusting the output amplitude of the square-wave generator as you switch the SENSITIVITY control from one setting to the next.

TABLE 6-3

SENSITIVITY	ADJUST
.2 VOLTS/CM	C306
.5 VOLTS/CM	C305B, C305C
5 VOLTS/CM	C304B, C304C

Connect the output of the square-wave generator through the 47- $\mu\mu\text{f}$ capacitance standardizer to the —INPUT connector. Set the —INPUT switch to the DC position and the +INPUT switch to the GND position. Set the SENSITIVITY switch to the positions indicated in Table 6-4 and adjust the corresponding capacitors for the best square-wave response.

TABLE 6-4

.2 VOLTS/CM	C316
.5 VOLTS/CM	C315B, C315C
5 VOLTS/CM	C314B, C314C

Disconnect the square-wave generator and the two jumper wires from the Type RM503 Oscilloscope.

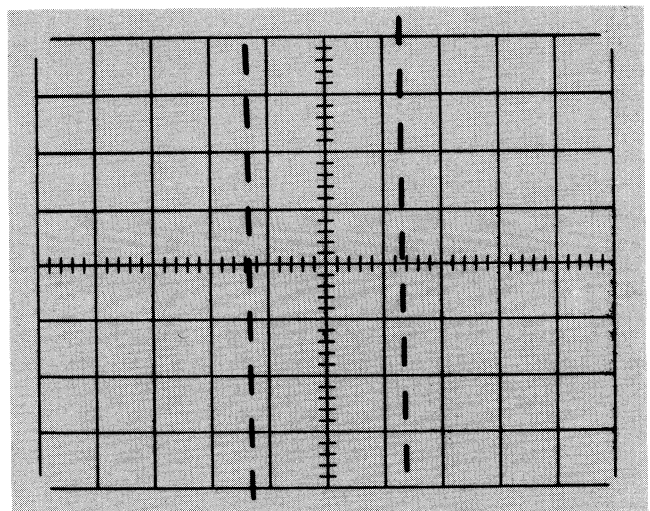

Fig. 6-5 Triggered vertical sweep.

Calibration—Type RM503

Amplifier Phasing (Type RM503, S/N 136 and up only)

16. 1 MV/CM PHASING.

Set the front panel controls as follows:

HORIZONTAL DISPLAY	HORIZ. AMP. ONLY
VERTICAL SENSITIVITY	1 MV/CM
+INPUT	GND
—INPUT	GND
HORIZONTAL SENSITIVITY	1 MV/CM
+INPUT	DC
—INPUT	GND

a. With Horizontal and Vertical DC BAL. controls, center the spot on the graticule. Connect a 50-ohm 5xT attenuator to the 190B Output and add a T connector to the attenuator. Connect a 52-ohm coaxial cable from the T connector outputs to the HORIZONTAL +INPUT and the VERTICAL +INPUT. Be sure the two cables are of equal length.

Set the 190B for 50 kc sine wave output and by adjusting the AMPLITUDE control and the attenuator box of the Type 190B, set the display on the Type RM503 to a 6 CM horizontal trace.

b. Change the output frequency of the Type 190B to 450 kc. Adjust C356 (See Fig. 6-6) so that the display is exactly 4.3 CM in length.

c. Change the vertical +INPUT to DC. This will make the display change to a straight line or extremely flattened ellipse at a 45° angle across the screen. Adjust the amplitude of the Type 190B to make the display 6 CM high. If the separation of the trace is greater than one minor graticule division at the widest part of the ellipse, adjust C456 (See Fig. 6-6) for one minor division or less of separation.

d. Change the output frequency of the Type 190B to 350 kc and adjust its amplitude for a 6 CM display. Trace separation should remain one minor graticule division or less.

e. Change the 190B Output frequency to 50 kc and adjust amplitude for 6 CM of display. Trace separation should be no more than one-half or .5 minor graticule division.

17. .2 VOLTS/CM PHASING.

a. Set both HORIZONTAL and VERTICAL SENSITIVITY controls to .2 VOLTS/CM. Set VERTICAL +INPUT to GND. Apply a 50 kc signal from the Type 190B to both Horizontal and Vertical +INPUTS. Adjust signal amplitude for 6 CM trace.

b. Change the 190B output to 450 kc. The display will contract somewhat. By changing the dress of horizontal deflection plate leads at the neck of the CRT, adjust the trace length to approximately 4.3 CM.

c. Set VERTICAL +INPUT switch to DC and adjust the Type 190B for a 6 CM display. Again, the display will be a diagonal line (45°) or flattened ellipse. Adjust C419 (See Fig. 6-) for a trace separation of 1 minor graticule division or less.

18. 20 MV/CM PHASING

a. Adjust Horizontal and Vertical SENSITIVITY settings to 20 MV/CM and adjust 450 kc Output of the Type 190B for a 6 CM display. If trace separation is greater than 1 minor graticule division, adjusting lead dress on the Vertical Deflection Plate Leads at the neck of the CRT should bring it within this limit.

b. Change the Type 190B Output to 350 kc and check for trace separation of one minor graticule division or less.

c. Change 190B to 50 kc and again check for one-half or .5 minor division or less of trace separation.

NOTE

Steps 16, 17 and 18 may interact, so after completion of all 3 steps it is necessary to recheck them once or twice to take care of any minor adjustments that may be needed.

19. ALL SENSITIVITIES PHASING.

It should not normally be necessary to check amplifier phasing at all Horizontal and Vertical SENSITIVITY settings after completing the three previous calibration steps. However, if you want to check phasing at the other settings, use the following procedures:

a. Set the 190B Output to 50 kc. Set Horizontal and Vertical SENSITIVITY to 2 MV/CM and HORIZONTAL +INPUT to GND. Adjust 190B amplitude for 6 CM of display. Change HORIZONTAL +INPUT to DC. Trace separation should be one-half or .5 minor graticule division or less.

Follow this same procedure with HORIZONTAL and VERTICAL SENSITIVITY set at each calibrated setting throughout the range. Then repeat using a 190B Output frequency of 350 kc, and again using 450 kc. When checking SENSITIVITY settings between 2 V/CM and 20 V/CM, it will be necessary to remove the 50-ohm attenuator at the 190B Output and replace it with a 50-ohm terminator in order to adjust your CRT display to the proper size.

NOTE

If you wish to actually measure the amount of phase shift indicated by the CRT display with both Horizontal and Vertical Inpputs applied to the scope, a good rule of thumb is that one minor graticule division of trace separation represents approximately 2° of phase shift for 6 CM display.

Sweep Generator

Set the front panel controls as follows:

SLOPE	+
COUPLING	AC
SOURCE	INT.
LEVEL	AUTO.
SWEEP TIME/CM	1 mSEC
VARIABLE*	CALIBRATED
HORIZONTAL DISPLAY	SWEEP NORMAL (X1)
VERTICAL	
+INPUT	DC
—INPUT	GND

*Make sure the SWEEP TIME/CM VARIABLE control is in the CALIBRATED position during all timing adjustments.

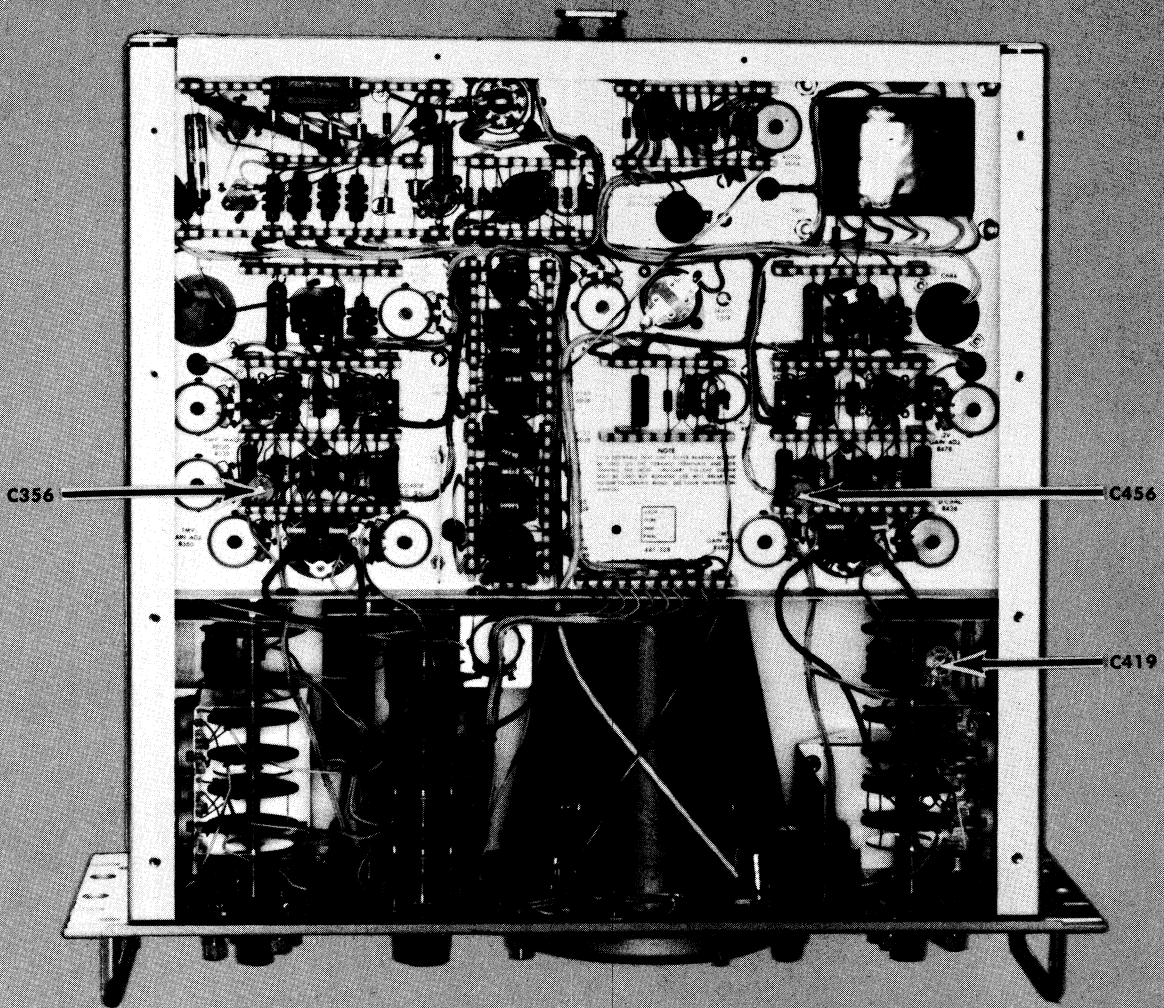

Fig. 6-6. Bottom view of the Type RM503 showing location of internal adjustments.

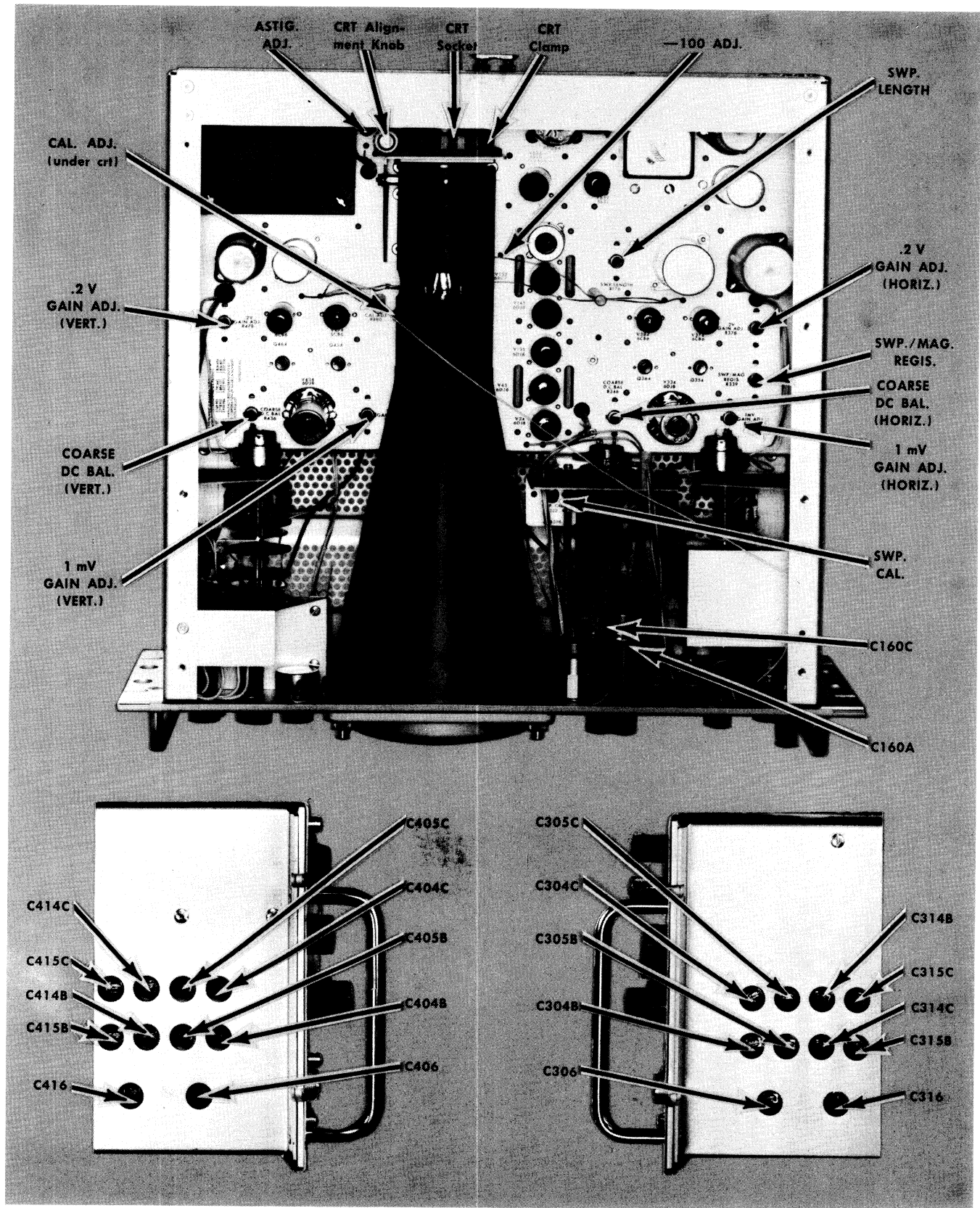

Fig. 6-7. Top view of the Type RM503 showing location of internal adjustments.

TABLE 6-5

SWEEP TIME/CM	TIME MARKERS	OBSERVE
.1 mSEC	100- μ sec	1 marker/cm
1 mSEC	1-msec	1 marker/cm
2 mSEC	1-msec	2 marker/cm
5 mSEC	5-msec	1 marker/cm
10 mSEC	10-msec	1 marker/cm
1. SEC	100-msec	1 marker/cm
1 SEC	1-sec	1 marker/cm
2 SEC	1-sec	2 marker/cm
5 SEC	5-sec	1 marker/cm

20. SWP. CAL. Apply 1-millisecond markers from the time-marker generator to the +INPUT connector of the Vertical Amplifier. Set the FOCUS, INTENSITY, POSITION, and VERTICAL SENSITIVITY controls for best presentation. Adjust the SWP. CAL. control (R322) for one marker per centimeter. (Use the HORIZONTAL POSITION control to align the markers with the graticule lines.) All sweep timing measurements in this and following steps should be made between the 1-centimeter and 9-centimeter graticule lines.

21. SWP. LENGTH. With 1-millisecond markers applied to the Vertical Amplifier, adjust the SWP. LENGTH control (R176) for a sweep length between 10.2 and 10.8 centimeters.

22. SWP/MAG. REGISTER. Set the HORIZONTAL DISPLAY switch to the X50 position and adjust the HORIZONTAL POSITION control to align the first marker with the center of the graticule. Then set the HORIZONTAL DISPLAY switch to the X1 position and adjust the SWP./MAG. REGIS. control (R339) to again align the first marker with the center of the graticule. Repeat this step until the marker remains horizontally centered as the HORIZONTAL DISPLAY switch is changed from X50 to X1.

23. CHECK SWEEP TIMING-5 SECONDS/CM to .1 MILLISECOND/CM. This step checks the accuracy of the sweep timing components for sweep rates between 5 seconds per centimeter and .1 millisecond per centimeter. There are no adjustments to be made. Table 6-5 lists the time markers to be applied for the indicated settings of the SWEEP TIME/CM switch and the number of markers per centimeter to be observed for each setting. When checking sweep rates between 1 SEC and 5 SEC, it will be necessary to adjust the LEVEL control for a stable display.

24. ADJUST SWEEP TIMING-10 MICROSECONDS/CM. Apply 10- μ sec markers from the time-mark generator to the +INPUT connector. Set the SWEEP TIME/CM control to the 10 μ sec position. Check to see that the SWEEP TIME/CM VARIABLE control is in the CALIBRATED position. Adjust the LEVEL control as required to obtain a stable display. Adjust C160C for 1 marker per centimeter on the crt screen.

25 ADJUST SWEEP TIMING-1 MICROSECOND/CM. Apply 1- μ sec markers from the time-marker generator to the +INPUT connector. Set the SWEEP TIME/CM control to 1 μ SEC position. Adjust the LEVEL, SENSITIVITY, and POSITION controls as required to obtain a stable display. Adjust C160A for 1 marker per centimeter on the crt screen. Disconnect the time-marker generator and replace the top and bottom covers.

SECTION 7

PARTS LIST and DIAGRAMS

PARTS ORDERING INFORMATION

Replacement parts are available from or through your local Tektronix Field Office.

Changes to Tektronix instruments are sometimes made to accommodate improved components as they become available, and to give you the benefit of the latest circuit improvements developed in our engineering department. It is therefore important, when ordering parts, to include the following information in your order: Part number including any suffix, instrument type, serial number, and modification number if applicable.

If a part you have ordered has been replaced with a new or improved part, your local Tektronix Field Office will contact you concerning any change in part number.

ABBREVIATIONS AND SYMBOLS

a or amp	amperes	mm	millimeter
BHS	binding head steel	meg or M	megohms or mega (10^6)
C	carbon	met.	metal
cer	ceramic	μ	micro, or 10^{-6}
cm	centimeter	n	nano, or 10^{-9}
comp	composition	Ω	ohm
cps	cycles per second	OD	outside diameter
crt	cathode-ray tube	OHS	oval head steel
CSK	counter sunk	p	pico, or 10^{-12}
dia	diameter	PHS	pan head steel
div	division	piv	peak inverse voltage
EMC	electrolytic, metal cased	plstc	plastic
EMT	electrolytic, metal tubular	PMC	paper, metal cased
ext	external	poly	polystyrene
f	farad	Prec	precision
F & I	focus and intensity	PT	paper tubular
FHS	flat head steel	PTM	paper or plastic, tubular, molded
Fil HS	fillister head steel	RHS	round head steel
g or G	giga, or 10^9	rms	root mean square
Ge	germanium	sec	second
GMV	guaranteed minimum value	Si	silicon
h	henry	S/N	serial number
hex	hexagonal	t or T	tera, or 10^{12}
HHS	hex head steel	TD	toroid
HSS	hex socket steel	THS	truss head steel
HV	high voltage	tub.	tubular
ID	inside diameter	v or V	volt
incd	incandescent	Var	variable
int	internal	w	watt
k or K	kilohms or kilo (10^3)	w/	with
kc	kilocycle	w/o	without
m	milli, or 10^{-3}	WW	wire-wound
mc	megacycle		

SPECIAL NOTES AND SYMBOLS

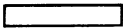
X000	Part first added at this serial number.
000X	Part removed after this serial number.
*000-000	Asterisk preceding Tektronix Part Number indicates manufactured by or for Tektronix, or reworked or checked components.
Use 000-000	Part number indicated is direct replacement.
	Internal screwdriver adjustment.
	Front-panel adjustment or connector.

EXPLODED VIEW

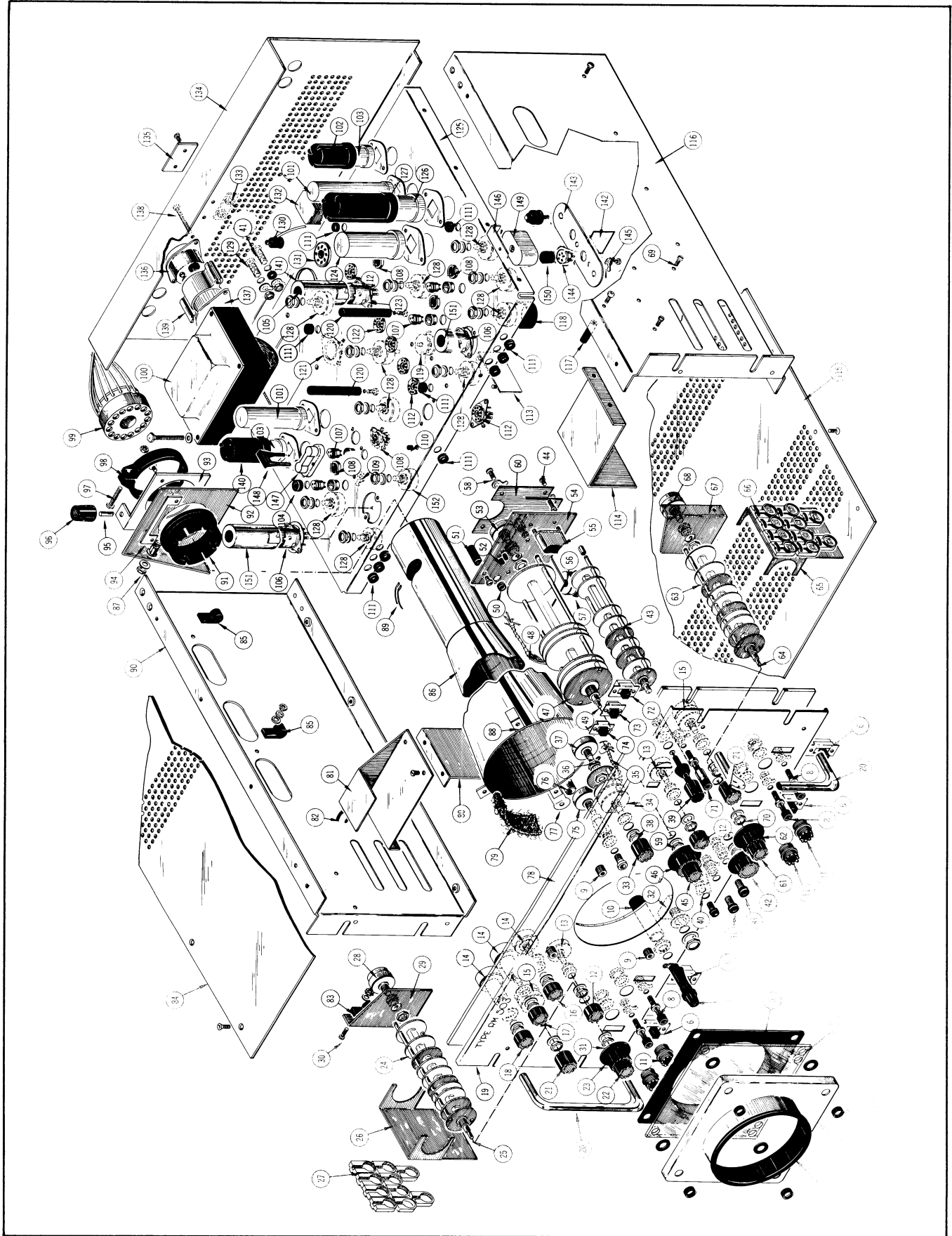

EXPLODED VIEW

REF. NO.	PART NO.	SERIAL/MODEL NO.		QTY.	DESCRIPTION
		EFF.	DISC.		
1	200-0382-00			1	COVER, graticule (see ref #3)
	- - - - -			-	cover includes:
2	354-0116-00			1	RING, ornamental
3	- - - - -			-	mounting hardware: (not included w/cover)
	210-0424-00			4	NUT, graticule
	210-0816-00			4	WASHER, rubber
4	331-0056-00			1	GRATICULE, 5 inches
5	337-0187-00			1	SHIELD, graticule light
6	260-0316-00	101	3789	4	SWITCH, slide—AC-DC-GND
	260-0448-00	3790		4	SWITCH, slide—AC-DC-GND
	- - - - -			-	mounting hardware for each: (not included w/switch)
	210-0406-00			2	NUT, hex, 4-40 x 3/16 inch
7	352-0007-00	101	1094	1	HOLDER, fuse
	352-0014-00	1095		1	HOLDER, fuse
8	129-0053-00			4	POST, binding
	- - - - -			-	each post includes:
	355-0507-00			1	STEM, adapter
	200-0103-00			1	CAP
	- - - - -			-	mounting hardware for each: (not included w/post)
	210-0223-00			1	LUG, solder, 1/4 inch
	210-0455-00			1	NUT, hex, 1/4-28 x 3/8 inch
9	355-0043-00			4	STUD, graticule (replacement)
	- - - - -			-	each stud includes:
	212-0507-00			1	SCREW, 10-32 x 3/8 inch BHS
	210-0010-00			1	LOCKWASHER, internal, #10
10	200-0237-00	101	2759X	1	COVER, insulation, fuse holder
11	131-0081-00			4	CONNECTOR, 1 contact, female, UHF
12	366-0101-00			2	KNOB, small gray—DC BAL.
	- - - - -			-	each knob includes:
	213-0004-00			1	SCREW, set, 6-32 x 3/16 inch HSS
13	- - - - -			2	POT
	- - - - -			-	mounting hardware for each: (not included w/pot)
	210-0413-00			2	NUT, hex, 3/8-32 x 1/2 inch
	210-0840-00			1	WASHER, .390 ID x 9/16 inch OD
	210-0012-00			1	LOCKWASHER, internal, 3/8 x 1/2 inch
14	- - - - -			3	POT
	- - - - -			-	mounting hardware for each: (not included w/pot)
	210-0413-00			1	NUT, hex, 3/8-32 x 1/2 inch
	210-0840-00			1	WASHER, .390 ID x 9/16 inch OD
	210-0013-00			1	LOCKWASHER, internal, 3/8 x 1 1/16 inch
15	- - - - -			2	POT
	- - - - -			-	mounting hardware for each: (not included w/pot)
	210-0413-00			1	NUT, hex, 3/8-32 x 1/2 inch
	210-0840-00			1	WASHER, .390 ID x 9/16 inch OD
	210-0012-00			1	LOCKWASHER, internal, 3/8 x 1/2 inch
	210-0207-00			1	LUG, solder, 3/8 inch

Parts List—Type RM503

EXPLODED VIEW (Cont'd)

REF. NO.	PART NO.	SERIAL/MODEL NO.		QTY.	DESCRIPTION
		EFF.	DISC.		
16	366-0033-00	101	1094	1	KNOB, small black—SCALE ILLUM.
	366-0134-00	1095	3789	1	KNOB, small black—SCALE ILLUM.
	366-0148-00	3790	5899	1	KNOB, small charcoal—SCALE ILLUM.
	366-0397-00	5900		1	KNOB, small charcoal—SCALE ILLUM.
	- - - - -			-	knob includes:
	213-0004-00			1	SCREW, set, 6-32 x 3/16 inch HSS
17	366-0033-00	101	1094	1	KNOB, small black—INTENSITY
	366-0134-00	1095	3789	1	KNOB, small black—INTENSITY
	366-0148-00	3790	5899	1	KNOB, small charcoal—INTENSITY
	366-0397-00	5900		1	KNOB, small charcoal—INTENSITY
	- - - - -			-	knob includes:
	213-0004-00			1	SCREW, set, 6-32 x 3/16 inch HSS
18	366-0033-00	101	1094	1	KNOB, small black—FOCUS
	366-0134-00	1095	3789	1	KNOB, small black—FOCUS
	366-0148-00	3790	5899	1	KNOB, small charcoal—FOCUS
	366-0397-00	5900		1	KNOB, small charcoal—FOCUS
	- - - - -			-	knob includes:
	213-0004-00			1	SCREW, set, 6-32 x 3/16 inch HSS
19	333-0608-00			1	PANEL, front
20	367-0008-00			2	HANDLE, drawer
	- - - - -			-	mounting hardware for each: (not included w/handle)
	212-0559-00			2	SCREW, 10-32 x 5/8 inch FHS
21	366-0044-00	101	3789	2	KNOB, small black—POSITION
	366-0113-00	3790		2	KNOB, small charcoal—POSITION
	- - - - -			-	each knob includes:
	213-0004-00			1	SCREW, set, 6-32 x 3/16 inch HSS
22	366-0031-00			1	KNOB, small red—VARIABLE
	- - - - -			-	knob includes:
	213-0004-00			1	SCREW, set, 6-32 x 3/16 inch HSS
23	366-0040-00	101	3789	1	KNOB, large black—VERTICAL SENSITIVITY
	366-0160-00	3790		1	KNOB, large charcoal—VERTICAL SENSITIVITY
	- - - - -			-	knob includes:
	213-0004-00			1	SCREW, set, 6-32 x 3/16 inch HSS
24	262-0347-00			1	SWITCH, wired—VERTICAL SENSITIVITY (see ref #30 & #31)
	- - - - -			-	switch includes:
	260-0318-00			1	SWITCH, unwired—VERTICAL SENSITIVITY
25	384-0209-00			1	ROD, extension
	376-0014-00			1	COUPLING, pot
26	406-0573-00			1	BRACKET, capacitor mounting
27	- - - - -			10	CAPACITOR
	- - - - -			-	mounting hardware for each: (not included w/capacitor alone)
	213-0034-00	101	408	2	SCREW, thread cutting, 4-40 x 5/16 inch, PHS
	214-0153-00	409		1	FASTENER, snap, double pronged
28	- - - - -			1	POT
	- - - - -			-	mounting hardware: (not included w/pot alone)
	210-0413-00			2	NUT, hex, 3/8-32 x 1/2 inch
	210-0012-00			1	LOCKWASHER, internal, 3/8 x 1/2 inch
29	406-0599-00			1	BRACKET, switch, attenuator, left
	- - - - -			-	mounting hardware: (not included w/bracket alone)
	210-0006-00			2	LOCKWASHER, internal, #6
	210-0407-00			2	NUT, hex, 6-32 x 1/4 inch
30	- - - - -			-	mounting hardware: (not included w/switch)
	211-0507-00			2	SCREW, 6-32 x 5/16 inch BHS
31	210-0012-00			1	LOCKWASHER, internal, 3/8 x 1/2 inch
	210-0413-00			1	NUT, hex, 3/8-32 x 1/2 inch

EXPLODED VIEW (Cont'd)

REF. NO.	PART NO.	SERIAL/MODEL NO.		QTY.	DESCRIPTION
		EFF.	DISC.		
32	260-0134-00			1	SWITCH, toggle—PWR. ON
	- - - - -			-	mounting hardware: (not included w/switch)
	210-0414-00			1	NUT, hex, $1\frac{5}{32}$ -32 x $\frac{9}{16}$ inch
	354-0055-00			1	RING, locking, switch
	210-0902-00			1	WASHER, .470 ID x $2\frac{1}{32}$ inch OD
	210-0473-00			1	NUT, switch, $1\frac{5}{32}$ -32 x $\frac{9}{64}$ inch, 12 sided
33	366-0044-00	101	3789	1	KNOB, small black—TRIGGER LEVEL
	366-0113-00	3790		1	KNOB, small charcoal—TRIGGER LEVEL
	- - - - -			-	knob includes:
	213-0004-00			1	SCREW, set, 6-32 x $\frac{3}{16}$ inch HSS
34	262-0351-00			1	SWITCH, wired—TRIGGER LEVEL (see ref #38)
	- - - - -			-	switch includes:
	260-0235-00			1	SWITCH, unwired—TRIGGER LEVEL
35	179-0472-00			1	CABLE HARNESS, trigger switch
36	376-0014-00			1	COUPLING, pot
37	- - - - -			1	POT
	- - - - -			-	mounting hardware: (not included w/pot alone)
	210-0413-00			2	NUT, hex, $\frac{3}{8}$ -32 x $\frac{1}{2}$ inch
	210-0012-00			1	LOCKWASHER, internal, $\frac{3}{8}$ x $\frac{1}{2}$ inch
38	- - - - -			-	mounting hardware: (not included w/switch)
	210-0012-00			1	LOCKWASHER, internal, $\frac{3}{8}$ x $\frac{1}{2}$ inch
	210-0840-00			1	WASHER, .390 ID x $\frac{9}{16}$ inch OD
	210-0413-00			1	NUT, hex, $\frac{3}{8}$ -32 x $\frac{1}{2}$ inch
39	129-0036-00	101	3789	1	POST, binding, black
	129-0063-00	3790		1	POST, binding, charcoal
	- - - - -			-	mounting hardware: (not included w/post)
	358-0036-00	101	3789	1	BUSHING, binding post, black
	358-0169-00	3790		1	BUSHING, binding post, charcoal
	210-0445-00	101	2629	2	NUT, hex, 10-32 x $\frac{3}{8}$ inch
	220-0410-00	2630		1	NUT, keps, 10-32 x $\frac{3}{8}$ inch
	210-0010-00	101	2629X	1	LOCKWASHER, internal, #10
	210-0206-00	101	2629X	1	LUG, solder, SE #10
40	136-0047-00			1	SOCKET, light
	210-0255-00	X3590		1	LUG, solder, $\frac{3}{8}$ inch
41	136-0106-00	101	1103	3	SOCKET, banana jack, black
	136-0138-00	1104	3789	3	SOCKET, banana jack, black
	136-0140-00	3790		3	SOCKET, banana jack, charcoal
	- - - - -			-	mounting hardware for each: (not included w/socket)
	210-0895-00			1	WASHER, insulating, shouldered
	210-0465-00			2	NUT, hex, $\frac{1}{4}$ -32 x $\frac{3}{8}$ inch
	210-0223-00			1	LUG, solder, $\frac{1}{4}$ inch
42	366-0042-00	101	3789	1	KNOB, large black—HORIZONTAL DISPLAY
	366-0117-00	3790		1	KNOB, large charcoal—HORIZONTAL DISPLAY
	- - - - -			-	knob includes:
	213-0004-00			1	SCREW, set, 6-32 x $\frac{3}{16}$ inch HSS
43	262-0350-00			1	SWITCH, wired—HORIZONTAL DISPLAY
	- - - - -			-	switch includes:
	260-0321-00	101	3439	1	SWITCH, unwired—HORIZONTAL DISPLAY
	260-0704-00	3440		1	SWITCH, unwired—HORIZONTAL DISPLAY
	- - - - -			-	mounting hardware: (not included w/switch)
	210-0012-00			1	LOCKWASHER, internal, $\frac{3}{8}$ x $\frac{1}{2}$ inch
	210-0413-00			1	NUT, hex, $\frac{3}{8}$ -32 x $\frac{1}{2}$ inch
44	211-0007-00			2	SCREW, 4-40 x $\frac{3}{16}$ inch BHS
	210-0004-00			2	LOCKWASHER, internal, #4

EXPLODED VIEW (Cont'd)

REF. NO.	PART NO.	SERIAL/MODEL NO.		QTY.	DESCRIPTION
		EFF.	DISC.		
45	366-0038-00			1	KNOB, small red—VARIABLE
	- - - - -			-	knob includes:
	213-0004-00			1	SCREW, set 6-32 x 3/16 inch HSS
46	366-0058-00	101	3789	1	KNOB, large black—SWEEP TIME/CM
	366-0144-00	3790		1	KNOB, large charcoal—SWEEP TIME/CM
	- - - - -			-	knob includes:
	213-0004-00			1	SCREW, set, 6-32 x 3/16 inch HSS
47	262-0349-00			1	SWITCH, wired—SWEEP TIME/CM (see ref #58 & #59)
	- - - - -			-	switch includes:
	260-0320-00			1	SWITCH, unwired—SWEEP TIME/CM
48	179-0450-00			1	CABLE HARNESS, SWEEP TIME/CM switch
49	384-0209-00			1	ROD, extension
	376-0014-00			1	COUPLING, pot
50	348-0003-00			2	GROMMET, 5/16 inch
51	385-0075-00	101	549	1	ROD, nylon
	385-0135-00	550		1	ROD, delrin
	- - - - -			-	mounting hardware: (not included w/rod alone)
	211-0507-00	101	549	1	SCREW, 6-32 x 5/16 inch BHS
	213-0054-00	550		1	SCREW, thread cutting, 6-32 x 5/16 inch PHS phillips
52	348-0031-00			2	GROMMET, 3/32 inch
53	- - - - -			1	POT
	- - - - -			-	mounting hardware: (not included w/pot alone)
	210-0413-00			2	NUT, hex, 3/8-32 x 1/2 inch
	210-0012-00			1	LOCKWASHER, internal, 3/8 x 1/2 inch
54	406-0598-00			1	BRACKET, timing capacitor
55	- - - - -			1	CAPACITOR
	- - - - -			-	mounting hardware: (not included w/capacitor alone)
	210-0006-00			2	LOCKWASHER, internal, #6
	210-0407-00			2	NUT, hex, 6-32 x 1/4 inch
56	- - - - -			1	POT
	- - - - -			-	mounting hardware: (not included w/pot alone)
	210-0840-00	X1910		1	WASHER, .390 ID x 3/16 inch OD
	210-0413-00	X1910		1	NUT, hex, 3/8-32 x 1/2 inch
57	200-0247-00	101	1909X	1	COVER, pot
58	- - - - -			-	mounting hardware: (not included w/switch)
	211-0029-00			2	SCREW, 5-40 x 3/16 inch PHS
	210-0004-00			1	LOCKWASHER, internal, #4
	210-0201-00			1	LUG, solder, SE #4
59	210-0012-00			1	LOCKWASHER, internal, 3/8 x 1/2 inch
	210-0413-00			1	NUT, hex, 3/8-32 x 1/2 inch
60	406-0597-00			1	BRACKET, switch, combination
	- - - - -			-	mounting hardware: (not included w/bracket)
	211-0507-00			2	SCREW, 6-32 x 5/16 inch BHS
	210-0202-00			1	LUG, solder, SE #6
61	366-0031-00			1	KNOB, small red—VARIABLE
	- - - - -			-	knob includes:
	213-0004-00			1	SCREW, set 6-32 x 3/16 inch HSS
62	366-0040-00	101	3789	1	KNOB, large black—HORIZONTAL SENSITIVITY
	366-0160-00	3790		1	KNOB, large charcoal—HORIZONTAL SENSITIVITY
	- - - - -			-	knob includes:
	213-0004-00			1	SCREW, set, 6-32 x 3/16 inch HSS

EXPLODED VIEW (Cont'd)

REF. NO.	PART NO.	SERIAL/MODEL NO.		QTY.	DESCRIPTION
		EFF.	DISC.		
63	262-0348-00	101	2209	1	SWITCH, wired—HORIZONTAL SENSITIVITY (see ref #69 & 70)
	262-0549-00	2210		1	SWITCH, wired—HORIZONTAL SENSITIVITY (see ref #69 & 70)
64	260-0319-00			-	switch includes:
	384-0209-00			1	SWITCH, unwired—HORIZONTAL SENSITIVITY
	376-0014-00			1	ROD, extension
65	406-0574-00			1	COUPLING, pot
66				1	BRACKET, capacitor mounting
				10	CAPACITOR
				-	mounting hardware for each: (not included w/capacitor alone)
	213-0034-00	101	408	2	SCREW, thread cutting, 4-40 x 5/16 inch, PHS
	214-0153-00	409		1	FASTENER, snap, double pronged
67	406-0600-00			1	BRACKET, switch, attenuator, right
				-	mounting hardware: (not included w/bracket alone)
	210-0006-00			2	LOCKWASHER, internal, #6
	210-0407-00			2	NUT, hex, 6-32 x 1/4 inch
68				1	POT
				-	mounting hardware: (not included w/pot alone)
	210-0413-00			2	NUT, hex, 3/8-32 x 1/2 inch
	210-0012-00			1	LOCKWASHER, internal, 3/8 x 1/2 inch
69				-	mounting hardware: (not included w/switch)
	211-0507-00			2	SCREW, 6-32 x 5/16 inch BHS
70	210-0012-00			1	LOCKWASHER, internal, 3/8 x 1/2 inch
	210-0413-00			1	NUT, hex, 3/8-32 x 1/2 inch
71	129-0051-00			1	POST, binding
				-	post includes:
	355-0507-00			1	STEM, adapter
	200-0182-00			1	CAP
				-	mounting hardware: (not included w/post)
	210-0223-00			1	LUG, solder, 1/4 inch
	210-0455-00			1	NUT, hex, 1/4-28 x 3/8 inch
72	260-0251-00	101	3789	1	SWITCH, slide—SOURCE
	260-0450-00	3790		1	SWITCH, slide—SOURCE
				-	mounting hardware: (not included w/switch)
	210-0406-00			2	NUT, hex, 4-40 x 3/16 inch
73	260-0145-00	101	3789	1	SWITCH, slide—COUPLING
	260-0449-00	3790		1	SWITCH, slide—COUPLING
				-	mounting hardware: (not included w/switch)
	210-0406-00			2	NUT, hex, 4-40 x 3/16 inch
74	260-0212-00	101	3789	1	SWITCH, slide—SLOPE
	260-0447-00	3790		1	SWITCH, slide—SLOPE
				-	mounting hardware: (not included w/switch)
	210-0406-00			2	NUT, hex, 4-40 x 3/16 inch
75				1	POT
				-	mounting hardware: (not included w/pot)
	210-0429-00			1	NUT, hex, 3/8-32 x 1/2 x 1 1/16 inches
	210-0013-00			1	LOCKWASHER, internal, 3/8 x 1 1/16 inch
	358-0010-00			1	BUSHING, 3/8-32 x 3/16 inch

EXPLODED VIEW (Cont'd)

REF. NO.	PART NO.	SERIAL/MODEL NO.		QTY.	DESCRIPTION
		EFF.	DISC.		
76	136-0035-00 ----- 211-0534-00 210-0803-00 210-0457-00			2 - 1 1 1	SOCKET, graticule light mounting hardware for each: (not included w/socket) SCREW, 6-32 x 5/16 inch PHS w/lockwasher WASHER, 6L x 3/8 inch NUT, keps, 6-32 x 5/16 inch
77	406-0239-00			3	BRACKET, crt spring
78	387-0262-00			1	PLATE, front subpanel
79	124-0022-00			1	STRIP, felt
80	337-0381-00 ----- 211-0507-00 210-0457-00			1 - 2 1	SHIELD, aluminum mounting hardware: (not included w/shield) SCREW, 6-32 x 5/16 inch BHS NUT, keps, 6-32 x 5/16 inch
81	337-0380-00 ----- 211-0507-00 211-0538-00			1 - 2 1	SHIELD, focus & intensity mounting hardware: (not included w/shield) SCREW, 6-32 x 5/16 inch BHS SCREW, 6-32 x 5/16 inch FHS phillips
82	348-0005-00	101	3349	1	GROMMET, 1/2 inch
	252-0562-00	3350		FT	STRIP, polyethylene extruded channel (1 9/16 inches)
83	343-0002-00 ----- 211-0511-00 210-0803-00 210-0457-00			1 - 1 2 1	CLAMP, cable, 3/16 inch mounting hardware: (not included w/clamp) SCREW, 6-32 x 1/2 inch BHS WASHER, 6L x 3/8 inch NUT, keps, 6-32 x 5/16 inch
84	387-0267-00 ----- 213-0041-00			1 - 8	PLATE, dust cover, top mounting hardware: (not included w/plate) SCREW, 6-32 x 1/4 inch FHS phillips
85	343-0042-00 ----- 211-0507-00 210-0803-00 210-0006-00 210-0407-00			2 - 1 1 1 1	CLAMP, cable, 5/16 inch (half) mounting hardware for each: (not included w/clamp) SCREW, 6-32 x 5/16 inch BHS WASHER, 6L x 3/8 inch LOCKWASHER, internal, #6 NUT, hex, 6-32 x 1/4 inch
86	337-0379-00 -----			1 -	SHIELD, crt mounting hardware: (not included w/shield)
87	211-0513-00 210-0006-00 166-0107-00 210-0803-00 210-0457-00			1 1 1 1 1	SCREW, 6-32 x 5/8 inch BHS LOCKWASHER, internal, #6 TUBE, spacing WASHER, 6L x 3/8 inch NUT keps, 6-32 x 5/16 inch
88	210-0006-00 210-0407-00			5 5	LOCKWASHER, internal, #6 NUT, hex, 6-32 x 1/4 inch
89	175-0582-00 175-0583-00 175-0584-00 175-0596-00			1 1 1 1	WIRE, crt lead, .458 foot, strip brown, w/connector WIRE, crt lead, 11 1/2 inches, strip red, w/connector WIRE, crt lead, 11 1/2 inches, striped green, w/connector WIRE, crt lead, .417 foot, striped blue, w/connector

EXPLODED VIEW (Cont'd)

REF. NO.	PART NO.	SERIAL/MODEL NO.		QTY.	DESCRIPTION
		EFF.	DISC.		
90	387-0271-00			1	PLATE, side, left
91	354-0078-00	101	1334	1	RING, crt rotator
	354-0178-00	1335		1	RING, crt rotator
92	406-0601-00			1	BRACKET, crt shield
	- - - - -			-	mounting hardware: (not included w/bracket)
	211-0507-00			4	SCREW, 6-32 x $\frac{5}{16}$ inch BHS
	210-0202-00			1	LUG, solder, SE #6
93	432-0022-00			1	BASE, crt rotator
	- - - - -			-	mounting hardware: (not included w/base)
	211-0561-00			2	SCREW, 6-32 x $\frac{3}{8}$ inch hex soc FH cap
94	210-0503-00			1	NUT, crt rotator, securing
95	355-0049-00			1	STUD, crt rotator
96	366-0032-00			1	KNOB, small red
	- - - - -			-	knob includes:
	213-0004-00			1	SCREW, set, 6-32 x $\frac{3}{16}$ inch HSS
97	211-0560-00			1	SCREW, 6-32 x 1 inch RHS
	210-0407-00			1	NUT, hex, 6-32 x $\frac{1}{4}$ inch
98	354-0103-00			1	RING, clamping
	- - - - -			-	ring includes:
	210-0502-00			1	NUT, crt rotator
99	136-0076-00	101	698	1	SOCKET, CRT
	387-0344-00	101	698	1	PLATE, CRT socket back
	211-0038-00	101	698	2	SCREW, 4-40 x $\frac{5}{16}$ inch, 100° csk, FHS
	136-0113-00	699		1	ASSEMBLY, crt socket
	- - - - -			-	assembly includes:
	136-0117-00			1	SOCKET, crt
	131-0178-00			9	CONNECTOR, cable end, crt
	387-0393-00			1	PLATE, back, crt socket
	- - - - -			-	mounting hardware: (not included w/plate alone)
	213-0086-00			2	SCREW, thread cutting, 2-32 x $\frac{7}{16}$ inch PHS
100	- - - - -			1	TRANSFORMER
	- - - - -			-	transformer includes: (mounting hardware)
	212-0517-00			4	SCREW, 10-32 x $1\frac{3}{4}$ inches HHS
	210-0812-00			4	WASHER, fiber, #10
	220-0410-00			4	NUT, keps, 10-32 x $\frac{3}{8}$ inch
101	- - - - -			2	CAPACITOR
	- - - - -			-	mounting hardware for each: (not included w/capacitor)
	386-0253-00			1	PLATE, metal, small capacitor
	211-0534-00			2	SCREW, 6-32 x $\frac{5}{16}$ inch PHS w/lockwasher
	210-0006-00			2	LOCKWASHER, internal, #6
	210-0407-00			2	NUT, hex, 6-32 x $\frac{1}{4}$ inch
102	200-0256-00			1	COVER, capacitor
103	- - - - -			2	CAPACITOR
	- - - - -			-	mounting hardware for each: (not included w/capacitor)
	386-0252-00			1	PLATE, fiber, small capacitor
	211-0534-00			2	SCREW, 6-32 x $\frac{5}{16}$ inch PHS w/lockwasher
	210-0006-00			2	LOCKWASHER, internal, #6
	210-0407-00			2	NUT, hex, 6-32 x $\frac{1}{4}$ inch
104	348-0004-00	101	5003	1	GROMMET, rubber, $\frac{3}{8}$ inch
	348-0056-00	5004		1	GROMMET, plastic, $\frac{3}{8}$ inch
105	337-0008-00			1	SHIELD, tube

Parts List—Type RM503

EXPLODED VIEW (Cont'd)

REF. NO.	PART NO.	SERIAL/MODEL NO.		QTY.	DESCRIPTION
		EFF.	DISC.		
106	136-0087-00 - - - - - 211-0033-00 210-0004-00 210-0406-00	101	5003X	2 - 2 2 2	SOCKET, 9 pin, w/shockmount spring mounting hardware for each: (not included w/socket) SCREW, 4-40 x 5/16 inch PHS w/lockwasher LOCKWASHER, internal, #4 NUT, hex, 4-40 x 3/16 inch
107	136-0095-00 136-0181-00 - - - - - 213-0113-00 354-0234-00	101 3240 101 3240	3239 3239	4 4 - 2 1	SOCKET, 4 pin transistor SOCKET, 3 pin transistor mounting hardware for each: (not included w/socket) SCREW, thread forming, 2-32 x 5/16 inch RHS phillips RING, locking, transistor socket
108	136-0008-00 - - - - - 213-0044-00			5 - 2	SOCKET, STM7G mounting hardware for each: (not included w/socket) SCREW, thread cutting, 5-32 x 3/16 inch PHS phillips
109	210-0201-00 - - - - - 213-0044-00			2 - 1	LUG, solder, SE #4 mounting hardware for each: (not included w/lug) SCREW, thread cutting, 5-32 x 3/16 inch PHS phillips
110	348-0031-00			6	GROMMET, 3/32 inch
111	348-0003-00 348-0067-00	101 5004	5003	11 11	GROMMET, rubber, 5/16 inch GROMMET, plastic, 5/16 inch
112	136-0015-00 - - - - - 213-0044-00			5 - 2	SOCKET, STM9G mounting hardware for each: (not included w/socket) SCREW, thread cutting, 5-32 x 3/16 inch PHS phillips
113	337-0388-00 - - - - - 210-0407-00 210-0006-00			1 - 4 2	SHIELD, chassis mounting hardware: (not included w/shield) NUT, hex, 6-32 x 1/4 inch LOCKWASHER, internal #6
114	337-0385-00 - - - - - 211-0507-00			1 - 2	SHIELD, trigger mounting hardware: (not included w/shield) SCREW, 6-32 x 5/16 inch BHS
115	387-0268-00 - - - - - 211-0541-00			1 - 10	PLATE, dust cover, bottom mounting hardware: (not included w/plate) SCREW, 6-32 x 1/4 inch FHS phillips
116	387-0270-00			1	PLATE, side, right
117	385-0073-00 385-0134-00 - - - - - 211-0507-00 213-0054-00	101 550 101 550	549 549	1 1 1 - 1 1	ROD, nylon ROD, delrin mounting hardware: (not included w/rod) SCREW, 6-32 x 5/16 inch BHS SCREW, thread cutting, 6-32 x 5/16 inch PHS phillips
118	200-0247-00	101	1909X	11	COVER, pot
119	214-0210-00 - - - - - 214-0209-00 - - - - - 361-0007-00	X549		1 - 1 - 1	ASSEMBLY, solder spool assembly includes: SPOOL, solder mounting hardware: (not included w/assembly) SPACER, nylon, .063 inch

EXPLODED VIEW (Cont'd)

REF. NO.	PART NO.	SERIAL/MODEL NO.		QTY.	DESCRIPTION
		EFF.	DISC.		
120	385-0147-00 ----- 211-0507-00			2 - 1	ROD, support mounting hardware for each: (not included w/rod) SCREW, 6-32 x 5/16 inch BHS
121	260-0336-00 ----- 213-0044-00			1 - 2	SWITCH, thermal cutout mounting hardware: (not included w/switch) SCREW, thread cutting, 5-32 x 3/16 inch PHS phillips
122	136-0015-00 136-0044-00 ----- 213-0044-00	101 2960	2959	1 1 - 2	SOCKET, STM9G SOCKET, 7 pin mounting hardware: (not included w/socket) SCREW, thread cutting, 5-32 x 3/16 inch PHS phillips
123	136-0022-00 ----- 211-0033-00 210-0004-00 210-0406-00			1 - 2 2 2	SOCKET, STM9S mounting hardware: (not included w/socket) SCREW, 4-40 x 5/16 inch PHS w/lockwasher LOCKWASHER, internal, #4 NUT, hex, 4-40 x 3/16 inch
124	----- ----- 386-0255-00 211-0534-00 210-0006-00 210-0407-00			1 - 1 2 2 2	CAPACITOR mounting hardware: (not included w/capacitor) PLATE, metal, large capacitor SCREW, 6-32 x 5/16 inch PHS w/lockwasher LOCKWASHER, internal, #6 NUT, hex, 6-32 x 1/4 inch
125	441-0328-00 441-0328-01 ----- 212-0004-00	101 5004	5003	1 1 - 13	CHASSIS, main CHASSIS, main mounting hardware: (not included w/chassis) SCREW, 8-32 x 5/16 inch BHS
126	----- ----- 386-0254-00 211-0543-00 210-0006-00 210-0407-00			1 - 1 2 2 2	CAPACITOR mounting hardware: (not included w/capacitor) PLATE, fiber, large capacitor SCREW, 6-32 x 5/16 inch RHS LOCKWASHER, internal, #6 NUT, hex, 6-32 x 1/4 inch
127	200-0258-00			1	COVER, capacitor
128	----- ----- 210-0840-00 210-0413-00	X1910 X1910		10 - 1 1	POT mounting hardware for each: (not included w/pot) WASHER, .390 ID x 9/16 inch OD NUT, hex, 3/8-32 x 1/2 inch
129	136-0106-00 136-0138-00 136-0140-00 ----- 210-0223-00 210-0465-00	101 1104 3790	1103 3789	1 1 1 - 1 1	SOCKET, banana jack, black SOCKET, banana jack, black SOCKET, banana jack, charcoal mounting hardware: (not included w/socket) LUG, solder, 1/4 inch NUT, hex, 1/4-32 x 3/8 inch
130	131-0142-00			1	CONNECTOR, cable end, tube
131	136-0011-00 ----- 213-0044-00			1 - 2	SOCKET, STM8 mounting hardware: (not included w/socket) SCREW, thread cutting, 5-32 x 3/16 inch PHS phillips

Parts List—Type RM503

EXPLODED VIEW (Cont'd)

REF. NO.	PART NO.	SERIAL/MODEL NO.		QTY.	DESCRIPTION
		EFF.	DISC.		
132	- - - - - - - - - - 211-0504-00			1 - 4	TRANSFORMER mounting hardware: (not included w/transformer) SCREW, 6-32 x 1/4 inch BHS
133	134-0012-00			1	PLUG, banana
134	387-0269-00 - - - - - 212-0004-00 212-0040-00 210-0008-00 210-0409-00			1 - 6 4 4 4	PLATE, back mounting hardware: (not included w/plate) SCREW, 8-32 x 5/16 inch BHS SCREW, 8-32 x 3/8 inch FHS phillips LOCKWASHER, internal, #8 NUT, hex, 8-32 x 5/16 inch
135	334-0649-00 - - - - - 213-0088-00			1 - 2	TAG, voltage rating mounting hardware: (not included w/tag) SCREW, thread forming, 4-40 x 1/4 inch PHS phillips
136	131-0102-00 - - - - - 129-0041-00 200-0185-00 210-0003-00 210-0551-00 211-0015-00 214-0078-00 377-0041-00			1 - 1 1 2 2 1 2 1	CONNECTOR, 3 wire motor base (see ref #138) connector includes: POST, ground COVER, motor base LOCKWASHER, external, #4 NUT, hex, 4-40 x 1/4 inch SCREW, 4-40 x 1/2 inch RHS PIN, connecting INSERT, black urea
137	386-0933-00			1	PLATE, motor base
138	- - - - - 211-0545-00 210-0006-00 210-0407-00			- 2 2 2	mounting hardware: (not included w/connector) SCREW, 6-32 x 1 1/4 inches THS phillips LOCKWASHER, internal, #6 NUT, hex, 6-32 x 1/4 inch
139	361-0012-00			1	SPACER, motor base
140	200-0256-00 200-0532-00	101 3830	3829	1 1 1	COVER, capacitor, 2 1/32 inches COVER, capacitor, 1 1/32 inches
141	348-0006-00 348-0050-00	101 5004	5003	1 1	GROMMET, rubber, 3/4 inch GROMMET, plastic, 3/4 inch
142	337-0736-00 - - - - - 213-0044-00	X5004		2 - 2	SHIELD, nuvistor mounting hardware for each: (not included w/shield) SCREW, thread forming, 5-32 x 3/16 inch, PHS
143	441-0609-01 - - - - - 348-0058-00 210-0457-00	X5004		2 - 2 2	CHASSIS, nuvistor mounting mounting hardware for each: (not included w/chassis) SHOCKMOUNT, rubber NUT, keps, 6-32 x 5/16 inch
144	136-0188-00 136-0131-00	X5004 5240	5239	4 4	SOCKET, 5 pin nuvistor SOCKET, 5 pin nuvistor

EXPLODED VIEW (Cont'd)

REF. NO.	PART NO.	SERIAL/MODEL NO.		QTY.	DESCRIPTION
		EFF.	DISC.		
145	210-0201-00 ----- 213-0044-00	X5004		2 - 1	LUG, solder, SE #4 mounting hardware for each: (not included w/lug) SCREW, thread forming, 5-32 x 3/16 inch, PHS
146	407-0142-00	X5004		2	BRACKET, shockmount stop
147	200-0497-00	X5004		2	COVER, transistor, temperature stabilizer
148	352-0072-00	X5004		2	HOLDER, transistor cover
149	200-0554-00 ----- 211-0517-00 210-0006-00	X5004		2 - 1 1	COVER, nuvistor, temperature stabilizer mounting hardware for each: (not included w/cover) SCREW, 6-32 x 1 inch, PHS LOCKWASHER, internal, #6
150	377-0103-00	X5004		4	INSERT, nuvistor cover
151	337-0008-00	101	5003X	2	SHIELD, tube
152	----- ----- 210-0840-00 210-0413-00 210-0012-00 210-0207-00	X1910 X1910 X5004 X5004		1 - 1 1 1 1	POT mounting hardware: (not included w/pot) WASHER, .390 ID x 3/16 inch OD NUT, hex, 3/8-32 x 1/2 inch LOCKWASHER, internal, 3/8 ID x 1/2 inch OD LUG, solder, 3/8 inch

CABLE HARNESS & CERAMIC STRIP DETAIL

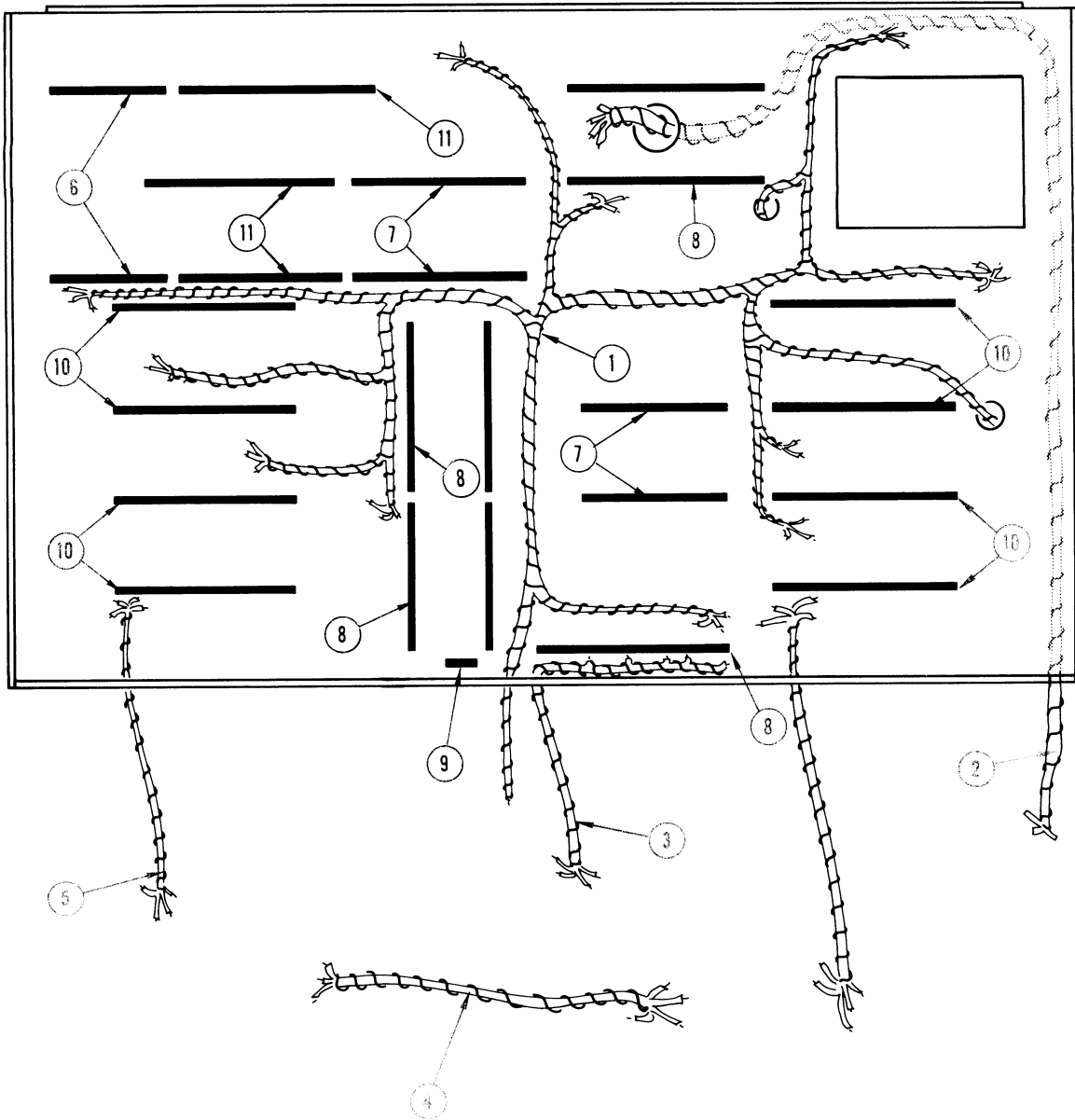

CABLE HARNESS & CERAMIC STRIP DETAIL

REF. NO.	PART NO.	SERIAL/MODEL NO.		QTY.	DESCRIPTION
		EFF.	DISC.		
1	179-0444-00	101	5003	1	CABLE HARNESS, chassis
	179-0444-01	5004		1	CABLE HARNESS, chassis
2	179-0447-00			1	CABLE HARNESS, focus & intensity
3	179-0445-00			1	CABLE HARNESS, subpanel #1
4	179-0446-00			1	CABLE HARNESS, subpanel #2
5	179-0452-00			2	CABLE HARNESS, sensitivity switch
6	124-0089-00	101	5339	2	STRIP, ceramic, $\frac{3}{4}$ inch x 7 notches
	124-0147-00	5340		2	STRIP, ceramic, $\frac{7}{16}$ inch x 13 notches
	-----			-	each strip includes:
	355-0046-00			2	STUD, nylon
	-----			-	mounting hardware for each: (not included w/strip)
	361-0009-00	101	5339	2	SPACER, nylon, .313 inch
	361-0008-00	5340		2	SPACER, nylon, .281 inch
7	124-0090-00			4	STRIP, ceramic, $\frac{3}{4}$ inch x 9 notches
	-----			-	each strip includes:
	355-0046-00			2	STUD, nylon
	-----			-	mounting hardware for each: (not included w/strip)
	361-0009-00			2	SPACER, nylon, .313 inch
8	124-0091-00			7	STRIP, ceramic, $\frac{3}{4}$ inch x 11 notches
	-----			-	each strip includes:
	355-0046-00			2	STUD, nylon
	-----			-	mounting hardware for each: (not included w/strip)
	361-0009-00			2	SPACER, nylon, .313 inch
9	124-0119-00			1	STRIP, ceramic, $\frac{7}{16}$ inch x 2 notches
	-----			-	strip includes:
	355-0046-00			1	STUD, nylon
	-----			-	mounting hardware: (not included w/strip)
	361-0007-00			1	SPACER, nylon, .063 inch
10	124-0091-00	101	5003	8	STRIP, ceramic, $\frac{3}{4}$ inch x 11 notches
	124-0154-00	5004		8	STRIP, ceramic, $\frac{7}{16}$ inch x 20 notches
	-----			-	each strip includes:
	355-0046-00	101	5003	2	STUD, nylon
	355-0082-00	5004		2	STUD, nylon
	-----			-	mounting hardware for each: (not included w/strip)
	361-0009-00	101	5003	2	SPACER, nylon, .313 inch
	361-0039-00	5004		2	SPACER, nylon, .531 inch
11	124-0091-00	101	5339	3	STRIP, ceramic, $\frac{3}{4}$ inch x 11 notches
	124-0145-00	5340		3	STRIP, ceramic, $\frac{7}{16}$ inch x 20 notches
	-----			-	each strip includes:
	355-0046-00			2	STUD, nylon
	-----			-	mounting hardware for each: (not included w/strip)
	361-0009-00	101	5339	2	SPACER, nylon, .313 inch
	361-0008-00	5340		2	SPACER, nylon, .281 inch

STANDARD ACCESSORIES

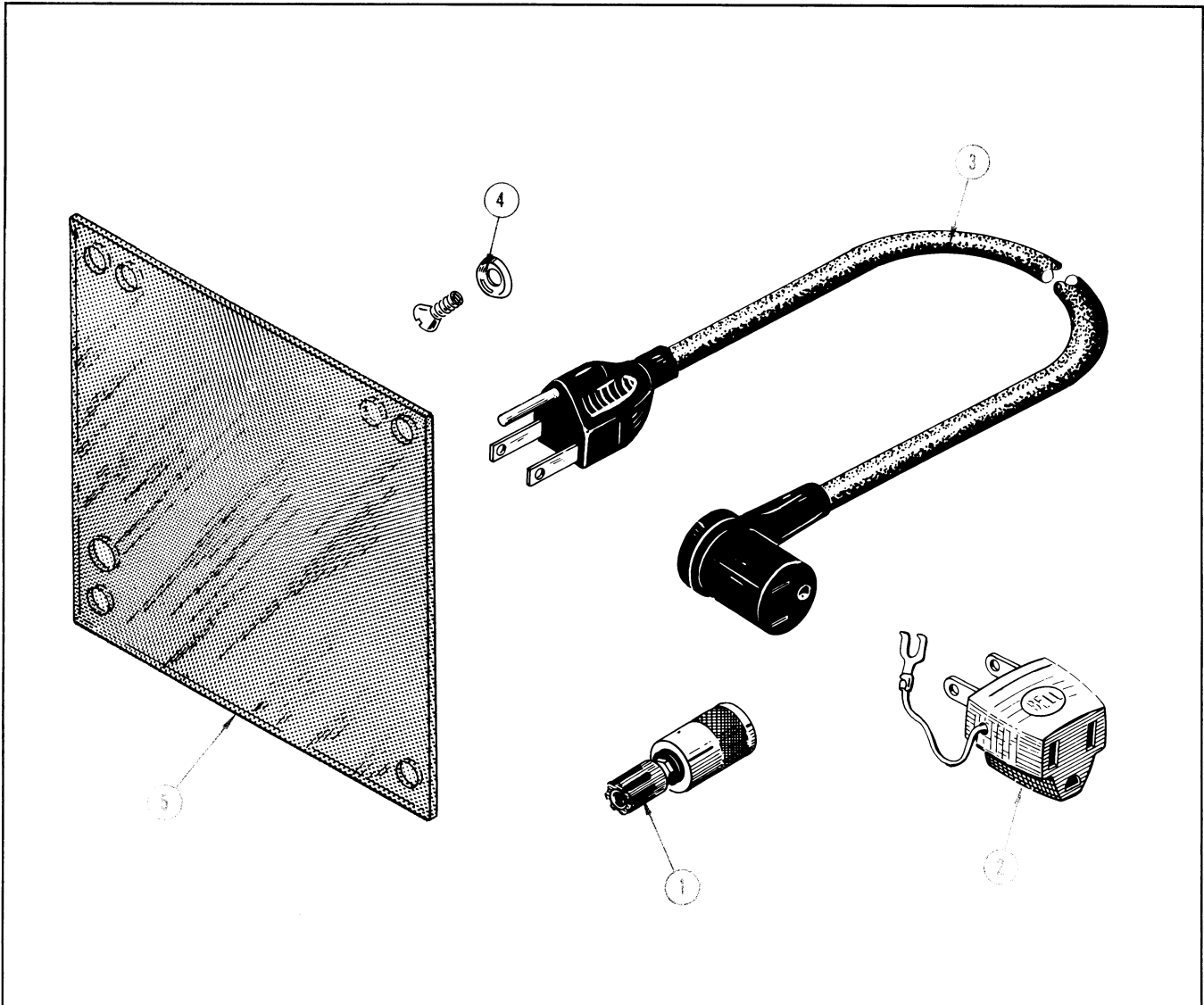

REF. NO.	PART NO.	SERIAL/MODEL NO.		QTY.	DESCRIPTION
		EFF.	DISC.		
1	013-0004-00			2	ADAPTER, binding post
2	103-0013-00			1	ADAPTER, power cord
3	161-0010-00	101	1424	1	CORD, power
	161-0013-00	1425	3179	1	CORD, power
	161-0022-00	3180	3859	1	CORD, power
	161-0024-00	3860		1	CORD, power
4	210-0833-00			4	WASHER, finishing, #10
	210-0917-00			4	WASHER, teflon
	212-0512-00			4	SCREW, 10-32 x 1/2 inch OHS
	212-0561-00			4	SCREW, 12-24 x 1/2 inch OHS
5	378-0514-00	X1204	5109	1	FILTER, light
	378-0567-00	5110		1	FILTER, light, smoke gray
--	070-0314-00			2	MANUAL, instruction (not shown)

ELECTRICAL PARTS LIST

Values are fixed unless marked Variable.

Ckt. No.	Tektronix Part Number	Description	S/N Range
Bulbs			
R167	150-002	Neon, Type NE-2	
B601	150-001	Incandescent, Type #47, Graticule Light	
B602	150-001	Incandescent, Type #47, Graticule Light	
B603	150-018	Incandescent, G.E. #12, Pilot Light	
B883	Use *150-009	Neon, Type NE-2, Aged and checked	
B886	Use *150-009	Neon, Type NE-2, Aged and checked	

Capacitors

Tolerance $\pm 20\%$ unless otherwise indicated.

Tolerance of all electrolytic capacitors as follows (with exceptions):

3 V — 50 V = -10% , $+250\%$
 51 V — 350 V = -10% , $+100\%$
 351 V — 450 V = $-10\frac{1}{2}\%$, $+50\%$

C10	283-001	.005 μ f	Disc Type		500 v	
C15	283-000	.001 μ f	Disc Type		500 v	
C20	283-000	.001 μ f	Disc Type		500 v	
C31	283-002	.01 μ f	Disc Type		500 v	
C37	281-510	22 pf	Cer.		500 v	
C43	281-518	47 pf	Cer.		500 v	
C112	283-001	.005 μ f	Disc Type		500 v	
C131	281-511	22 pf	Cer.		500 v	10%
C141	281-501	4.7 pf	Cer.		500 v	± 1 pf
C160A	281-007	3-12 pf	Cer.	Var.	500 v	
C160B	Use 281-574	82 pf	Cer.		500 v	10%
C160C	281-010	4.5-25 pf	Cer.	Var.	500 v	
C160D	*291-008	.001 μ f	Mylar			$\pm \frac{1}{2}\%$
C160E	*291-029	.01 μ f	Mylar Timing Series			$\pm \frac{1}{2}\%$
C160F		.1 μ f				
C160G		1 μ f				
C167	283-000	.001 μ f	Disc Type		500 v	
C181	281-509	15 pf	Cer.		500 v	10%
C300†	*295-063	.022 μ f	PTM	Selected	600 v	
C304B	281-012	7-45 pf	Cer.	Var.	500 v	
C304C	281-005	1.5-7 pf	Cer.	Var.	500 v	
C304E	281-560	198 pf	Cer.		500 v	10%
C305B	281-012	7-45 pf	Cer.	Var.	500 v	
C305C	281-005	1.5-7 pf	Cer.	Var.	500 v	
C306	Use 281-0010-00	4.5-25 pf	Cer.	Var.	500 v	
C306	281-0005-00	1.5-7 pf	Cer.	Var.		101-5003 5004-up
C308A	281-503	8 pf	Cer.		500 v	± 0.5 pf X550-up

†C300 and C310 selected $\pm 5\%$ each other. Furnished as a unit.

Parts List — Type RM503

Capacitors (continued)

Ckt. No.	Tektronix Part Number		Description			S/N Range
C308C	281-542	18 pf	Cer.		500 v	10% X550-up
C308E	281-583	47 pf	Cer.		500 v	5% X750-1094X
C308G	281-584	100 pf	Cer.		500 v	5% X750-1094X
C308J	281-585	270 pf	Cer.		500 v	5% X750-1094X
C308L	283-524	750 pf	Mica		500 v	5% X750-1094X
C308N	283-555	2000 pf	Mica		500 v	1% X750-1094X
C310†	*295-063	.022 μ f	PTM	Selected	600 v	
C314B	281-012	7-45 pf	Cer.	Var.	500 v	
C314C	281-005	1.5-7 pf	Cer.	Var.	500 v	
C314E	281-560	198 pf	Cer.		500 v	10%
C315B	281-012	7-45 pf	Cer.	Var.	500 v	
C315C	281-005	1.5-7 pf	Cer.	Var.	500 v	
C316	Use 281-0010-00	4.5-25 pf	Cer.	Var.	500 v	101-5003
C316	281-0007-00	3-12 pf	Cer.	Var.		5004-up
C327	283-001	.005 μ f	Disc Type		500 v	
C330	283-001	.005 μ f	Disc Type		500 v	
C336	283-001	.005 μ f	Disc Type		500 v	
C340	283-001	.005 μ f	Disc Type		500 v	
C346	283-001	.005 μ f	Disc Type		500 v	
C350	281-518	47 pf	Cer.		500 v	
C353	283-012	.1 μ f	Disc Type		100 v	
C356	281-029	1.5-7 pf	Cer.	Var.	350 v	101-5003
C356	281-0027-00	.7-3 pf	Tub.	Var.		5004-up
C357	281-542	18 pf	Cer.		500 v	10% 101-1094
C357	281-505	12 pf	Cer.		500 v	10% 1095-up
C360	281-518	47 pf	Cer.		500 v	
C365	281-0547-00	2.7 pf	Cer.		500 v	10% X5004-up
C366	281-500	2.2 pf	Cer.		500 v	\pm .5 pf 101-1094X
C367	281-542	18 pf	Cer.		500 v	10% 101-1094
C367	281-505	12 pf	Cer.		500 v	10% 1095-up
C368	281-0034-00	1.5-7 pf	Cer.	Var.		X5004-up
C379	281-543	270 pf	Cer.		500 v	10% X400-up
C390	Use 281-537	.68 pf	Cer.		500 v	\pm .136 pf 101-5003X
C400††	*295-063	.022 μ f	PTM	Selected	600 v	
C404B	281-012	7-45 pf	Cer.	Var.	500 v	
C404C	281-005	1.5-7 pf	Cer.	Var.	500 v	
C404E	281-560	198 pf	Cer.		500 v	10%
C405B	281-012	7-45 pf	Cer.	Var.	500 v	
C405C	281-005	1.5-7 pf	Cer.	Var.	500 v	
C406	281-010	4.5-25 pf	Cer.	Var.	500 v	101-5003
C406	281-0007-00	3-12 pf	Cer.	Var.		5004-up
C408A	281-503	8 pf	Cer.		500 v	\pm 0.5 pf X550-up
C408C	281-542	18 pf	Cer.		500 v	10% X550-up
C408E	281-583	47 pf	Cer.		500 v	5% X750-1094X
C408G	281-584	100 pf	Cer.		500 v	5% X750-1094X
C408J	281-585	270 pf	Cer.		500 v	5% X750-1094X
C408L	283-524	750 pf	Mica		500 v	5% X750-1094X
C408N	283-555	2000 pf	Mica		500 v	1% X750-1094X
C410††	*295-063	.022 μ f	PTM	Selected	600 v	
C414B	281-012	7-45 pf	Cer.	Var.	500 v	

†C300 and C310 selected \pm 5% each other. Furnished as a unit.

††C400 and C410 selected \pm 5% each other. Furnished as a unit.

Resistors (continued)

Ckt. No.	Tektronix Part Number		Description			S/N Range
R28	304-333	33 k	1 w			101-1134
	310-070	33 k	1 w	Prec.	1%	1135-up
R34	302-681	680 Ω	$\frac{1}{2}$ w			
R35	302-272	2.7 k	$\frac{1}{2}$ w			
R36	302-471	470 Ω	$\frac{1}{2}$ w			X320-up
R37	309-055	370 k	$\frac{1}{2}$ w	Prec.	1%	
R38	309-003	500 k	$\frac{1}{2}$ w	Prec.	1%	
R40	302-275	2.7 meg	$\frac{1}{2}$ w			
R43	302-472	4.7 k	$\frac{1}{2}$ w			
R44	302-103	10 k	$\frac{1}{2}$ w			
R46	304-223	22 k	1 w			
R111	311-112	15 k		Var.		STABILITY ADJUST
R112	301-273	27 k	$\frac{1}{2}$ w			5%
R113	301-513	51 k	$\frac{1}{2}$ w			5%
R134	309-043	82 k	$\frac{1}{2}$ w	Prec.	1%	
R135	301-184	180 k	$\frac{1}{2}$ w			5%
R137	302-101	100 Ω	$\frac{1}{2}$ w			
R141	309-045	100 k	$\frac{1}{2}$ w	Prec.	1%	
R143	309-136	25.6 k	$\frac{1}{2}$ w	Prec.	1%	
R144	309-153	20 k	$\frac{1}{2}$ w	Prec.	1%	
R146	302-101	100 Ω	$\frac{1}{2}$ w			
R147	302-152	1.5 k	$\frac{1}{2}$ w			101-5159
R147	302-0102-00	1 k	$\frac{1}{2}$ w			5160-up
R160A	309-014	1 meg	$\frac{1}{2}$ w	Prec.	1%	
R160B	309-023	2 meg	$\frac{1}{2}$ w	Prec.	1%	
R160C	309-087	5 meg	$\frac{1}{2}$ w	Prec.	1%	
R160D	309-095	10 meg	$\frac{1}{2}$ w	Prec.	1%	
R160E	309-095	10 meg	$\frac{1}{2}$ w	Prec.	1%	
R160F	310-505	30 meg	2 w	Prec.	1%	
R160X	302-823	82 k	$\frac{1}{2}$ w			
R160Y	311-182	200 k		Var.		VARIABLE
R164	304-154	150 k	1 w			
R167	302-105	1 meg	$\frac{1}{2}$ w			
R168	302-104	100 k	$\frac{1}{2}$ w			
R171	302-101	100 Ω	$\frac{1}{2}$ w			
R174	304-273	27 k	1 w			
R176	Use 311-368	5 k	$\frac{1}{2}$ w	Var.		SWP. LENGTH
R178	302-822	8.2 k	$\frac{1}{2}$ w			
R181	302-475	4.7 meg	$\frac{1}{2}$ w			
R304C	309-145	990 k	$\frac{1}{2}$ w	Prec.	1%	101-5899
R304C	323-0614-00	990 k	$\frac{1}{2}$ w	Prec.	1%	5900-up
R304E	318-009	10.1 k	$\frac{1}{8}$ w	Prec.	1%	101-5899
R304E	321-0614-00	10.1 k	$\frac{1}{8}$ w	Prec.	1%	5900-up
R305C	309-142	900 k	$\frac{1}{2}$ w	Prec.	1%	101-5899
R305C	323-0611-00	900 k	$\frac{1}{2}$ w	Prec.	1%	5900-up
R305E	318-006	111 k	$\frac{1}{8}$ w	Prec.	1%	101-5899
R305E	321-0617-00	111 k	$\frac{1}{8}$ w	Prec.	1%	5900-up
R306	309-014	1 meg	$\frac{1}{2}$ w	Prec.	1%	
R308A	309-100	10 k	$\frac{1}{2}$ w	Prec.	1%	
R308C	309-283	3.33 k	$\frac{1}{2}$ w	Prec.	1%	
R308E	309-284	1.11 k	$\frac{1}{2}$ w	Prec.	1%	
R308G	309-285	526 Ω	$\frac{1}{2}$ w	Prec.	1%	
R308J	309-286	256 Ω	$\frac{1}{2}$ w	Prec.	1%	
R308L	309-287	101 Ω	$\frac{1}{2}$ w	Prec.	1%	
R308N	309-128	50 Ω	$\frac{1}{2}$ w	Prec.	1%	101-319
R308N	309-216	50.9 Ω	$\frac{1}{2}$ w	Prec.	1%	320-up

Parts List — Type RM503

Resistors (continued)

Ckt. No.	Tektronix Part No.		Description			S/N Range
R314C	309-145	990 k	1/2 w			
R314C	323-0614-00	990 k	1/2 w	Prec.	1%	101-5899
R314E	318-009	10.1 k	1/8 w	Prec.	1%	5900-up
R314E	321-0614-00	10.1 k	1/8 w	Prec.	1%	101-5899
R315C	309-142	900 k	1/2 w	Prec.	1%	5900-up
R315C	323-0611-00	900 k	1/2 w	Prec.	1%	101-5899
R315E	318-006	111 k	1/8 w			
R315E	321-0617-00	111 k	1/8 w	Prec.	1%	101-5899
R316	309-014	1 meg	1/2 w	Prec.	1%	5900-up
R318A	309-100	10 k	1/2 w	Prec.	1%	
R318C	309-181	2.5 k	1/2 w	Prec.	1%	
R318E	309-284	1.11 k	1/2 w	Prec.	1%	
R318G	309-285	526 Ω	1/2 w			
R318J	309-237	204 Ω	1/2 w	Prec.	1%	
R319	309-290	21.5 k	1/2 w	Prec.	1%	
R320	309-243	193 k	1/2 w	Prec.	1%	
R321	309-270	3.92 k	1/2 w	Prec.	1%	
R322	Use 311-0372-00	750 Ω	1/2 w	Var.		SWP. CAL.
R326	302-475	4.7 meg	1/2 w			
R327	Use 301-184	180 k	1/2 w			5%
R330	302-104	100 k	1/2 w			
R331	302-471	470 Ω	1/2 w			
R334	309-090	50 k	1/2 w	Prec.	1%	
R336	311-181	250 Ω	1/2 w	Var.		DC BAL
R337	302-680	68 Ω	1/2 w			101-5003
R337	302-0101-00	100 Ω	1/2 w			5004-up
R338	310-074	38.3 k	1 w			
R339	Use 311-365	1 k	1/2 w	Var.	Prec.	1% SWP/MAG. REGIS.
R340	302-104	100 k	1/2 w			
R341	302-471	470 Ω	1/2 w			
R344	309-090	50 k	1/2 w			
R346	Use 311-367	250 Ω	1/2 w	Var.	Prec.	1% COARSE DC BAL.
R347	302-680	68 Ω	1/2 w			101-5003
R347	302-0101-00	100 Ω	1/2 w			5004-up
R348	310-074	38.3 k	1 w			
R350	302-152	1.5 k	1/2 w	Prec.	1%	
R351	301-911	910 Ω	1/2 w			5% X1095-up
R352	303-822	8.2 k	1 w			5%
R353	301-103	10 k	1/2 w			5% 101-549
R353	301-682	6.8 k	1/2 w			5% 550-1094
R353	301-103	10 k	1/2 w			5% 1095-up
R354	301-332	3.3 k	1/2 w			5% X550-1094X
R355	303-333	33 k	1 w			5% X1095-up
R356	316-394	390 k	1/4 w			
R357	309-228	12.5 k	1/2 w			
R358	302-105	1 meg	1/2 w	Prec.	1%	
R360	Use 311-364	20 k	1/2 w	Var.		1 MV GAIN ADJ.
R365	302-0470-00	47 Ω	1/2 w			X5004-up
R366	316-394	390 k	1/4 w			
R367	309-228	12.5 k	1/2 w			
R368	302-105	1 meg	1/2 w	Prec.	1%	
R370	311-190	2 x 20 k	1/2 w			
R371	302-101	100 Ω	1/2 w	Var.		POSITION

Resistors (continued)

Ckt. No.	Tektronix Part No.		Description			S/N Range
R373	308-105	30 k	8 w	WW	5%	
R376	308-108	15 k	5 w	WW	5%	
R377	306-123	12 k	2 w			
R378	Use 311-363	2 k		Var.	.2 V GAIN ADJ.	101-289
R378	Use 311-365	750 Ω	1/2 w	Var.		290-up
R379	309-102	402 Ω	1/2 w	Prec.	1%	X290-up
R381	302-101	100 Ω	1/2 w			
R383	308-105	30 k	8 w	WW	5%	
R386	308-108	15 k	5 w	WW	5%	
R387	306-123	12 k	2 w			
R388	Use 311-375	2.5 k		Var.	WW	VARIABLE
R404C	309-145	990 k	1/2 w	Prec.	1%	101-5899
R404C	323-0614-00	990 k	1/2 w	Prec.	1%	5900-up
R404E	318-009	10.1 k	1/8 w	Prec.	1%	101-5899
R404E	321-0614-00	10.1 k	1/8 w	Prec.	1%	5900-up
R405C	309-142	900 k	1/2 w	Prec.	1%	101-5899
R405C	323-0611-00	900 k	1/2 w	Prec.	1%	5900-up
R405E	318-006	111 k	1/8 w	Prec.	1%	101-5899
R405E	321-0617-00	111 k	1/8 w	Prec.	1%	5900-up
R406	309-014	1 meg	1/2 w	Prec.	1%	
R408A	309-100	10 k	1/2 w	Prec.	1%	
R408C	309-283	3.33 k	1/2 w	Prec.	1%	
R408E	309-284	1.11 k	1/2 w	Prec.	1%	
R408G	309-285	526 Ω	1/2 w	Prec.	1%	
R408J	309-286	256 Ω	1/2 w	Prec.	1%	
R408L	309-287	101 Ω	1/2 w	Prec.	1%	
R408N	309-128	50 Ω	1/2 w	Prec.	1%	101-319
R408N	309-216	50.9 Ω	1/2 w	Prec.	1%	320-up
R414C	309-145	990 k	1/2 w	Prec.	1%	101-5899
R414C	323-0614-00	990 k	1/2 w	Prec.	1%	5900-up
R414E	318-009	10.1 k	1/8 w	Prec.	1%	101-5899
R414E	321-0614-00	10.1 k	1/8 w	Prec.	1%	5900-up
R415C	309-142	900 k	1/2 w	Prec.	1%	101-5899
R415C	323-0611-00	900 k	1/2 w	Prec.	1%	5900-up
R415E	318-006	111 k	1/8 w	Prec.	1%	101-5899
R415E	321-0617-00	111 k	1/8 w	Prec.	1%	5900-up
R416	309-014	1 meg	1/2 w	Prec.	1%	
R419	309-290	21.5 k	1/2 w	Prec.	1%	
R430	302-104	100 k	1/2 w			
R431	302-471	470 Ω	1/2 w			
R434	309-090	50 k	1/2 w			
R436	Use 311-367	250 Ω		Var.	1% COARSE DC BAL.	
R437	302-680	68 Ω	1/2 w			101-5003
R437	302-0101-00	100 Ω	1/2 w			5004-up
R438	310-074	38.3 k	1 w	Prec.	1%	
R440	302-104	100 k	1/2 w			
R441	302-471	470 Ω	1/2 w			
R444	309-090	50 k	1/2 w	Prec.	1%	
R446	311-181	250 Ω	1/2 w	Var.	DC BAL.	
R447	302-680	68 Ω	1/2 w			101-5003
R447	302-0101-00	100 Ω	1/2 w			5004-up
R448	310-074	38.3 k	1 w	Prec.	1%	
R450	302-152	1.5 k	1/2 w			
R451	301-911	910 Ω	1/2 w		5%	X1095-up
R452	303-822	8.2 k	1 w		5%	101-5379

Parts List — Type RM503

Resistors (continued)

Ckt. No.	Tektronix Part No.		Description			S/N Range
R452	303-0432-00	4.3 k	1 w		5%	5380-up
R453	301-103	10 k	1/2 w		5%	101-549
R453	301-682	6.8 k	1/2 w		5%	550-1094
R453	301-103	10 k	1/2 w		5%	1095-5379
R453	301-0153-00	15 k	1/2 w		5%	5380-up
R454	301-332	3.3 k	1/2 w		5%	X550-1094X
R455	303-333	33 k	1 w		5%	X1095-up
R456	316-394	390 k	1/4 w			
R457	309-228	12.5 k	1/2 w			
R458	302-105	1 meg	1/2 w	Prec.	1%	
R459	301-0332-00	3.3 k	1/2 w		5%	X5380-up
R460	Use 311-364	20 k	1/2 w	Var.		1 MV GAIN ADJ.
R465	302-0470-00	47 Ω	1/2 w			X5004-up
R466	316-394	390 k	1/4 w			
R467	309-228	12.5 k	1/2 w			
R468	302-105	1 meg	1/2 w			
R470	311-190	2 x 20 k		Var.		POSITION
R471	302-101	100 Ω	1/2 w			
R473	308-105	30 k	8 w		WW	5%
R476	308-108	15 k	5 w		WW	5%
R477	306-123	12 k	2 w			
R478	Use 311-363	2 k		Var.		.2 V GAIN ADJ. 101-289
	Use 311-372	750 Ω	1/2 w	Var.		290-up
R479	309-102	402 Ω	1/2 w		Prec.	X290-up
R481	302-101	100 Ω	1/2 w			
R483	308-105	30 k	8 w		WW	5%
R486	308-108	15 k	5 w		WW	5%
R487	306-123	12 k	2 w			
R488	311-189	2 k		Var.		VARIABLE
R490	302-474	470 k	1/2 w			
R491	302-473	47 k	1/2 w			
R492	302-334	330 k	1/2 w			
R601	311-055	50 Ω		Var.	WW	SCALE ILLUM. 101-1094
	311-262	50 Ω		Var.	WW	1095-up
R605	302-473	47 k	1/2 w			
R606	302-101	100 Ω	1/2 w			X430-up
R607	302-101	100 Ω	1/2 w			X430-up
R611	304-154	150 k	1 w			
R612	304-154	150 k	1 w			
R621	302-104	100 k	1/2 w			
R623	302-472	4.7 k	1/2 w			
R624	302-220	22 Ω	1/2 w			
R626	308-168	40 k	8 w		WW	5%
R628	302-471	470 Ω	1/2 w			X520-up
R630	302-684	680 k	1/2 w			
R631	302-225	2.2 meg	1/2 w			
R632	302-101	100 Ω	1/2 w			
R634	302-333	33 k	1/2 w			
R635	302-563	56 k	1/2 w			
R637	302-474	470 k	1/2 w			
R640	309-234	154 k	1/2 w		Prec.	1% 101-5189

Resistors (continued)

Ckt. No.	Tektronix Part No.	Description	S/N Range
R640	323-0391-00	115 k $\frac{1}{2}$ w	Prec. 1% 5190-up
R641	Use 311-403	20 k $\frac{1}{2}$ w	Var. —100 V ADJ.
R642	309-151	174 k $\frac{1}{2}$ w	Prec. 1% 101-5189
R642	323-0396-00	130 k $\frac{1}{2}$ w	Prec. 1% 5190-up
R644	302-474	470 k $\frac{1}{2}$ w	
R646	302-153	15 k $\frac{1}{2}$ w	
R659	302-104	100 k $\frac{1}{2}$ w	101-5189
R659	303-0513-00	51 k 1 w	5% 5190-up
R692	307-056	4.3 Ω $\frac{1}{2}$ w	5%
R840	304-824	820 k 1 w	
R841	304-824	820 k 1 w	
R842	304-824	820 k 1 w	
R844	311-041	1 meg	Var. FOCUS 101-1094
	311-261	1 meg	Var. FOCUS 1095-up
R845	302-474	470 k $\frac{1}{2}$ w	
R847	311-188	500 k	Var. INTENSITY 101-519
	311-242	200 k	Var. 520-1094
	311-264	200 k	Var. 1095-up
R849	302-473	47 k $\frac{1}{2}$ w	
R851	302-155	1.5 meg $\frac{1}{2}$ w	
R852	302-225	2.2 meg $\frac{1}{2}$ w	
	302-155	1.5 meg $\frac{1}{2}$ w	101-519
R854	302-104	100 k $\frac{1}{2}$ w	520-up
R857	Use 302-393	39 k $\frac{1}{2}$ w	
R858	302-104	100 k $\frac{1}{2}$ w	
R860	302-224	220 k $\frac{1}{2}$ w	
R862	302-104	100 k $\frac{1}{2}$ w	
R864	Use 311-366	500 k $\frac{1}{2}$ w	Var. ASTIGMATISM
R880	Use 311-366	500 k $\frac{1}{2}$ w	Var. CAL. ADJ.
R881	309-019	1.75 meg $\frac{1}{2}$ w	Prec. 1%
R883	302-225	2.2 meg $\frac{1}{2}$ w	
R886	309-239	4.95 k $\frac{1}{2}$ w	Prec. 1%
R887	309-128	50 Ω $\frac{1}{2}$ w	Prec. 1% 101-319
	309-215	49.5 Ω $\frac{1}{2}$ w	Prec. 1% 320-up

Switches

	Unwired	Wired			S/N Range
SW5	260-251		Slide	SOURCE	101-3789
SW5	260-0450-00		Slide	SOURCE	3790-up
SW10	260-145		Slide	COUPLING	101-3789
SW10	260-0449-00		Slide	COUPLING	3790-up
SW17	260-235	*262-351	Rotary	TRIG. LEVEL	
SW20	260-212		Slide	SLOPE	101-3789
SW20	260-0447-00		Slide	SLOPE	3790-up
SW160	260-320	*262-349	Rotary	TIME/CM	
SW300	260-316		Slide	AC/DC + INPUT	101-3789
SW300	260-0448-00		Slide	AC/DC + INPUT	3790-up
SW304	260-319	use *262-549	Rotary	HORIZ. SENS.	
SW310	260-316		Slide	AC/DC — INPUT	101-3789
SW310	260-0448-00		Slide	AC/DC — INPUT	3790-up
SW410	260-316		Slide	AC/DC + INPUT	101-3789
SW410	260-0448-00		Slide	AC/DC + INPUT	3790-up

Parts List — Type RM503

Switches (Cont)

Ckt. No.	Tektronix Part No.	Description	S/N Range
SW601	260-134	Toggle POWER OFF	
TK601	260-336	Thermal Cutout 150°	
SW318	Use 260-704 *262-350	Rotary HORIZ. DISPLAY	
SW400	260-316	Slide AC/DC — INPUT	101-3789
SW400	260-0448-00	Slide AC/DC — INPUT	3790-up
SW404	260-318 *262-347	Rotary VERT. SENS.	

Transformers

T601	*050-039	L. V. Power	101-429
T601	*120-203	L. V. Power	430-up
T620	Use *120-199	H. V. Power	

Transistors

Q354	151-045	2N1637	101-1094
Q354	Use 050-0251-00	Replacement Kit	1095-3479
Q354	*151-133	Selected from 2N3251	3480-up
Q364	151-045	2N1637	101-1094
Q364	Use 050-0251-00	Replacement Kit	1095-3479
Q364	*151-133	Selected from 2N3251	3480-up
Q454	151-045	2N1637	101-1094
Q454	Use 050-0251-00	Replacement Kit	1095-3479
Q454	*151-133	Selected from 2N3251	3480-up
Q464	151-045	2N1637	101-1094
Q464	Use 050-0251-00	Replacement Kit	1095-3479
Q464	*151-133	Selected from 2N3251	3480-up

Electron Tubes

V24	154-187	6DJ8	
V45	154-187	6DJ8	
V135	154-187	6DJ8	
V145	154-187	6DJ8	
V152	Use 154-0453-00	6BJ7	101-2959
V152	154-016	6AL5	2960-up
V160	154-278	6BL8/ECF80	
V334	Use *157-066	6DJ8	Checked
V334 } V344 }	*157-0109-00	8393	Checked pair
V374	154-030	6CB6	
V384	154-030	6CB6	
V434	Use *157-066	6DJ8	Checked
V434 } V444 }	*157-0109-00	8393	Checked pair
V474	154-030	6CB6	
V484	154-030	6CB6	
V620	154-277	6DQ6	
V634	154-278	6BL8/ECF80	
V659	154-052	5651	
V692	154-051	5642	
V859	*154-265	T5030-2 CRT Standard Phosphor	

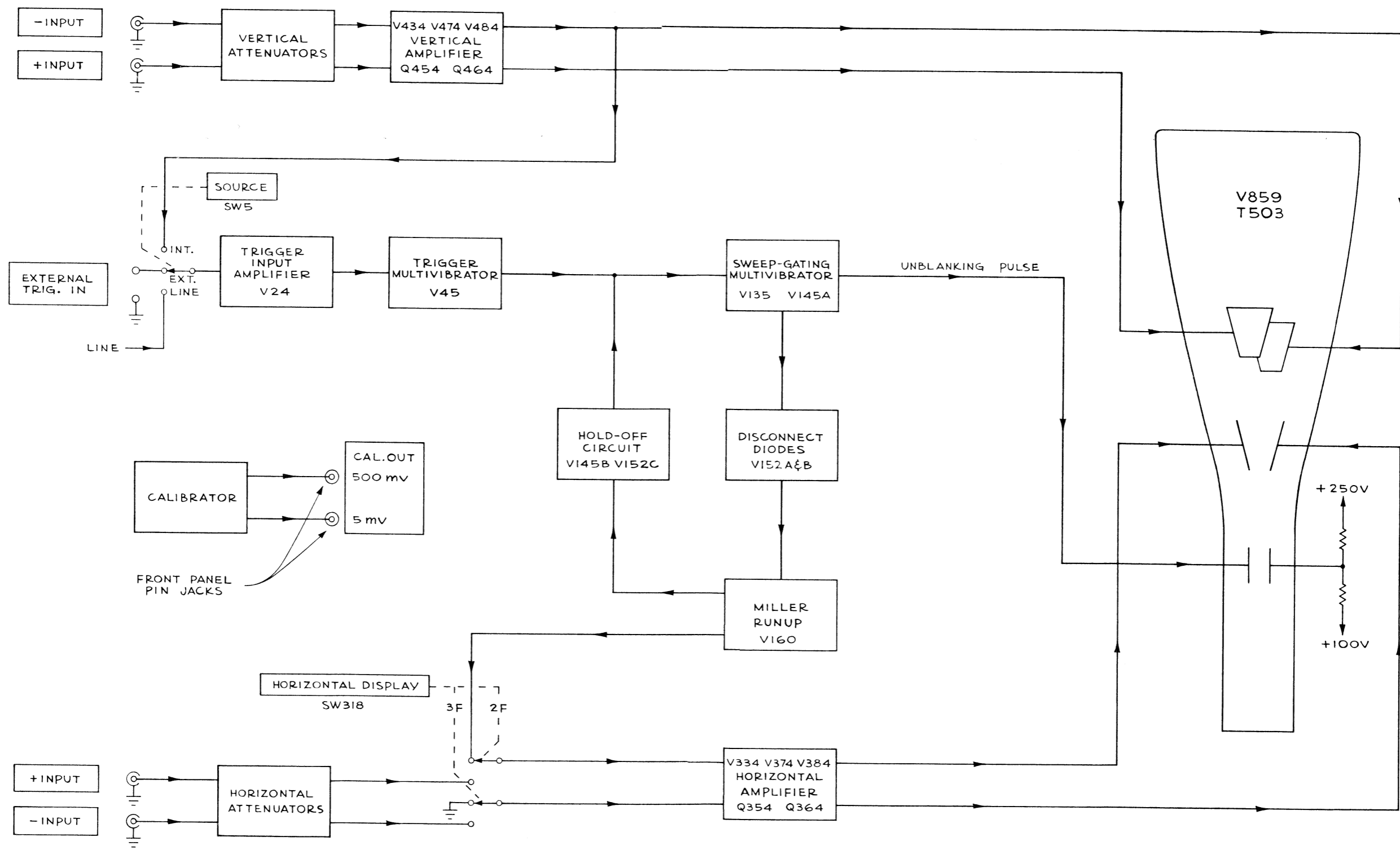

TYPE RM503 OSCILLOSCOPE

A

BLOCK DIAGRAM

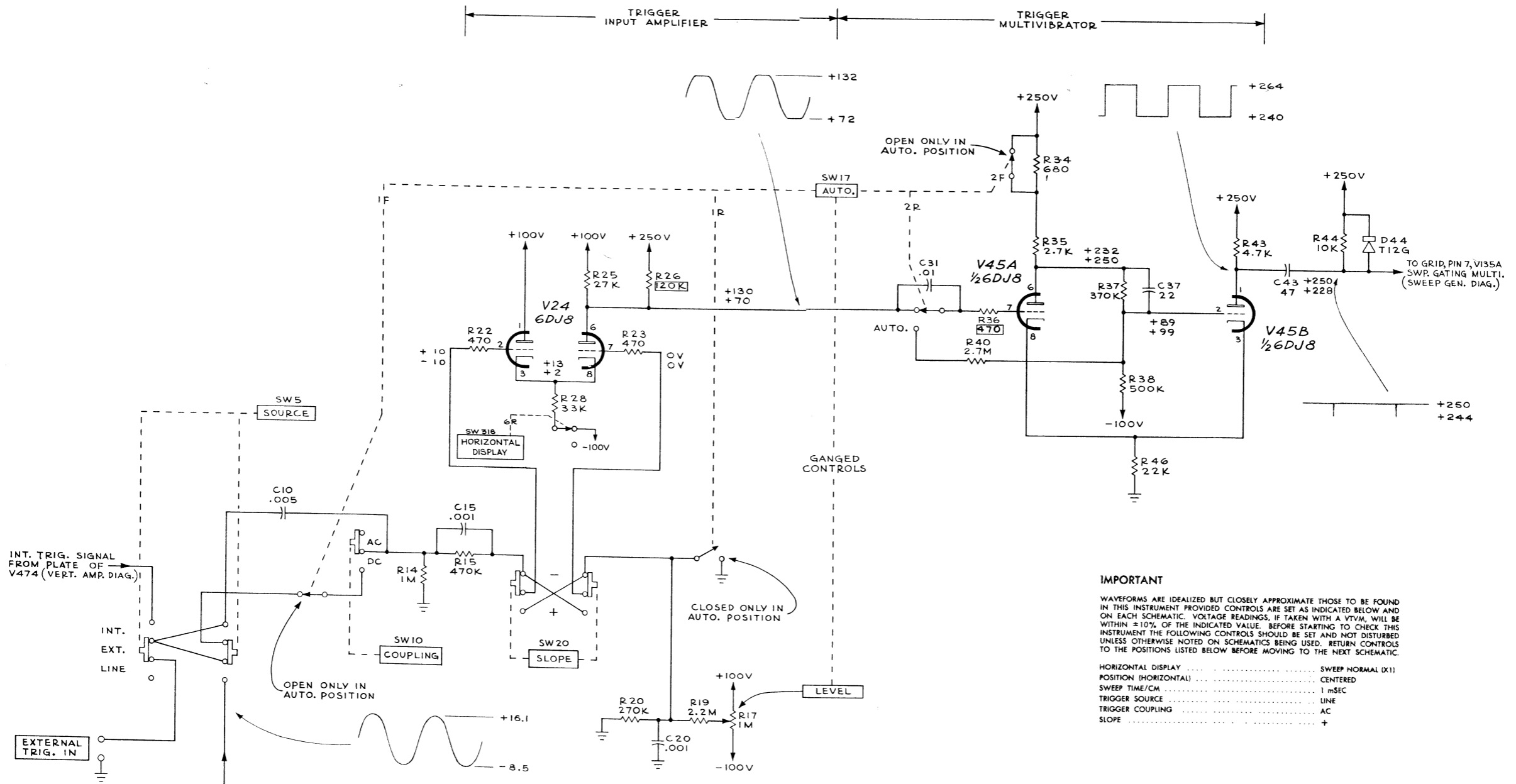

IMPORTANT

WAVEFORMS ARE IDEALIZED BUT CLOSELY APPROXIMATE THOSE TO BE FOUND IN THIS INSTRUMENT PROVIDED CONTROLS ARE SET AS INDICATED BELOW AND ON EACH SCHEMATIC. VOLTAGE READINGS, IF TAKEN WITH A VTVM, WILL BE WITHIN ±10% OF THE INDICATED VALUE. BEFORE STARTING TO CHECK THIS INSTRUMENT THE FOLLOWING CONTROLS SHOULD BE SET AND NOT DISTURBED UNLESS OTHERWISE NOTED ON SCHEMATICS BEING USED. RETURN CONTROLS TO THE POSITIONS LISTED BELOW BEFORE MOVING TO THE NEXT SCHEMATIC.

- HORIZONTAL DISPLAY SWEEP NORMAL (X1)
- POSITION (HORIZONTAL) CENTERED
- SWEEP TIME/CM 1 mSEC
- TRIGGER SOURCE LINE
- TRIGGER COUPLING AC
- SLOPE +

WAVEFORMS AND VOLTAGE READINGS
 WERE OBTAINED WITH CONTROLS SET AS FOLLOWS:

TRIGGER LEVEL
 FOR WAVEFORMS CENTERED
 FOR UPPER VOLTAGE READINGS FREE RUN
 FOR LOWER VOLTAGE READINGS CCW BUT NOT SWITCHED TO AUTO

SEE ALSO IMPORTANT NOTE ON THIS DIAGRAM

SEE PARTS LIST FOR EARLIER VALUES AND S/N CHANGES OF PARTS MARKED WITH BLUE OUTLINE.

TYPE RM503 OSCILLOSCOPE

A₂

SWEEP TRIGGER

CIRCUIT NUMBERS
 10 THRU 49

GAB
 364

SWEEP TRIGGER

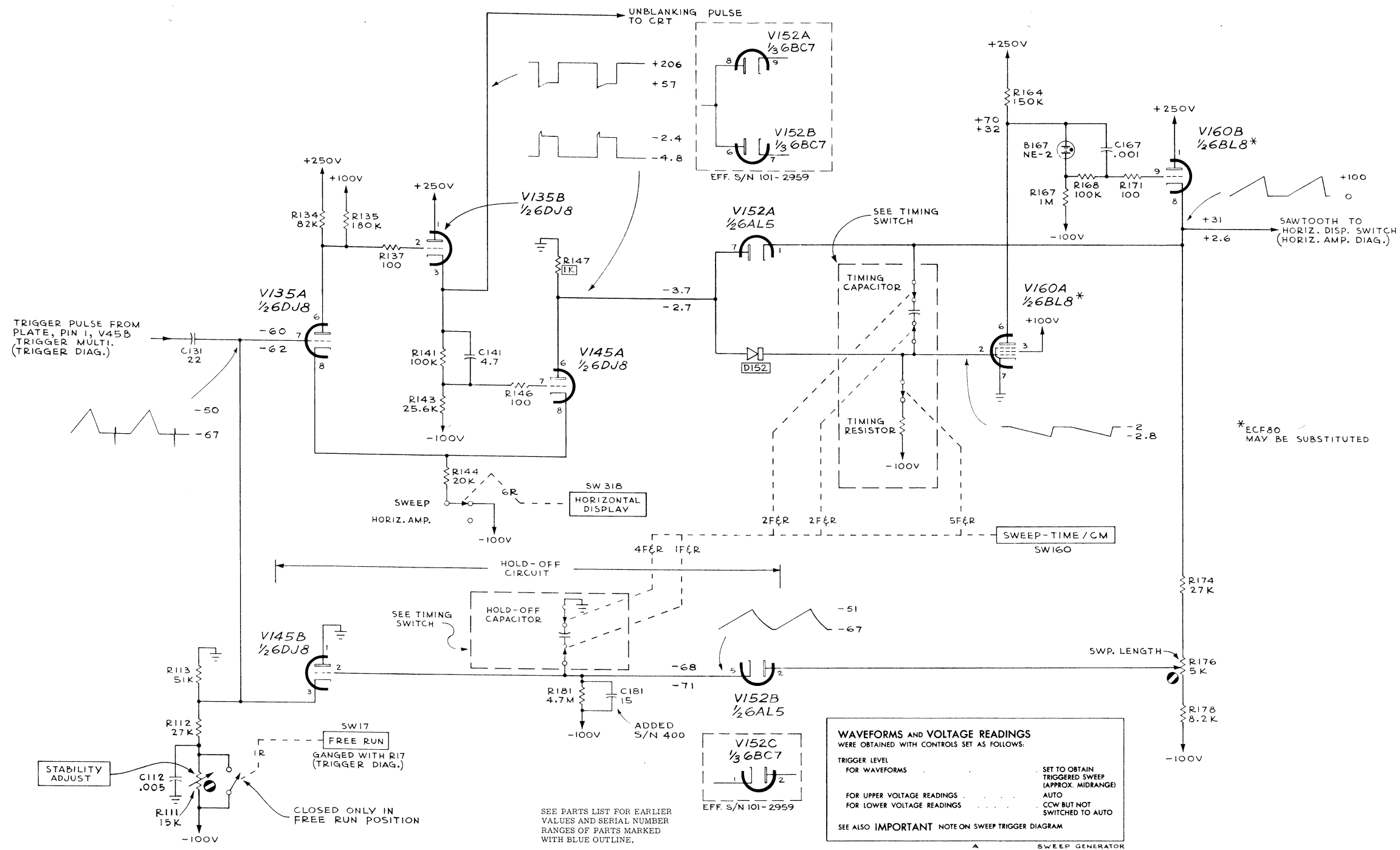
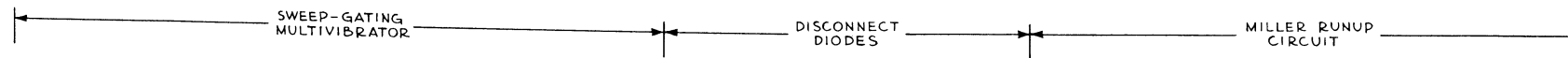

TYPE RM503 OSCILLOSCOPE

SWEEP GENERATOR

SWEEP GENERATOR

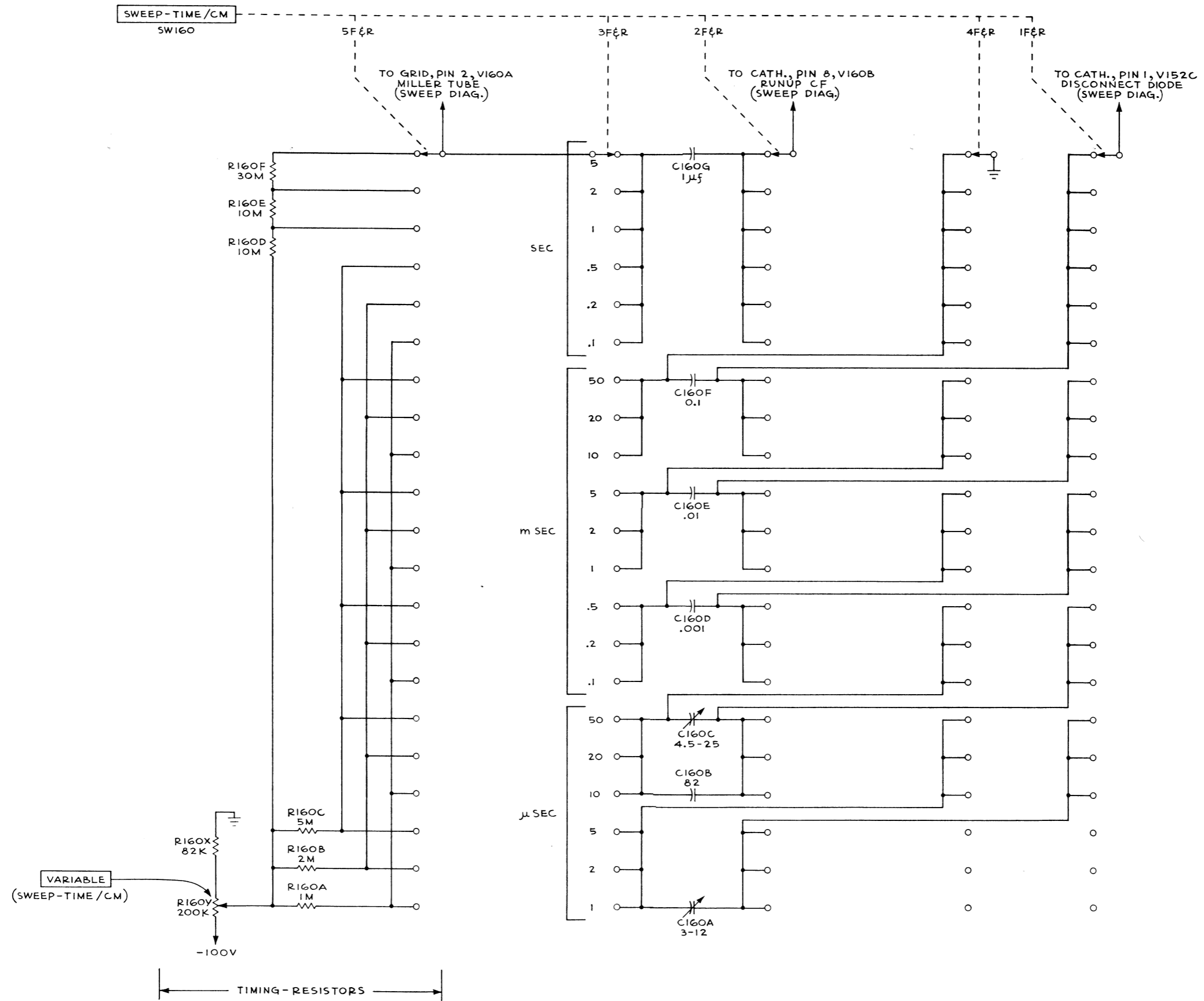

TYPE RM503 OSCILLOSCOPE

A

GAB
12-18-62
TIMING SWITCH

TIMING SWITCH

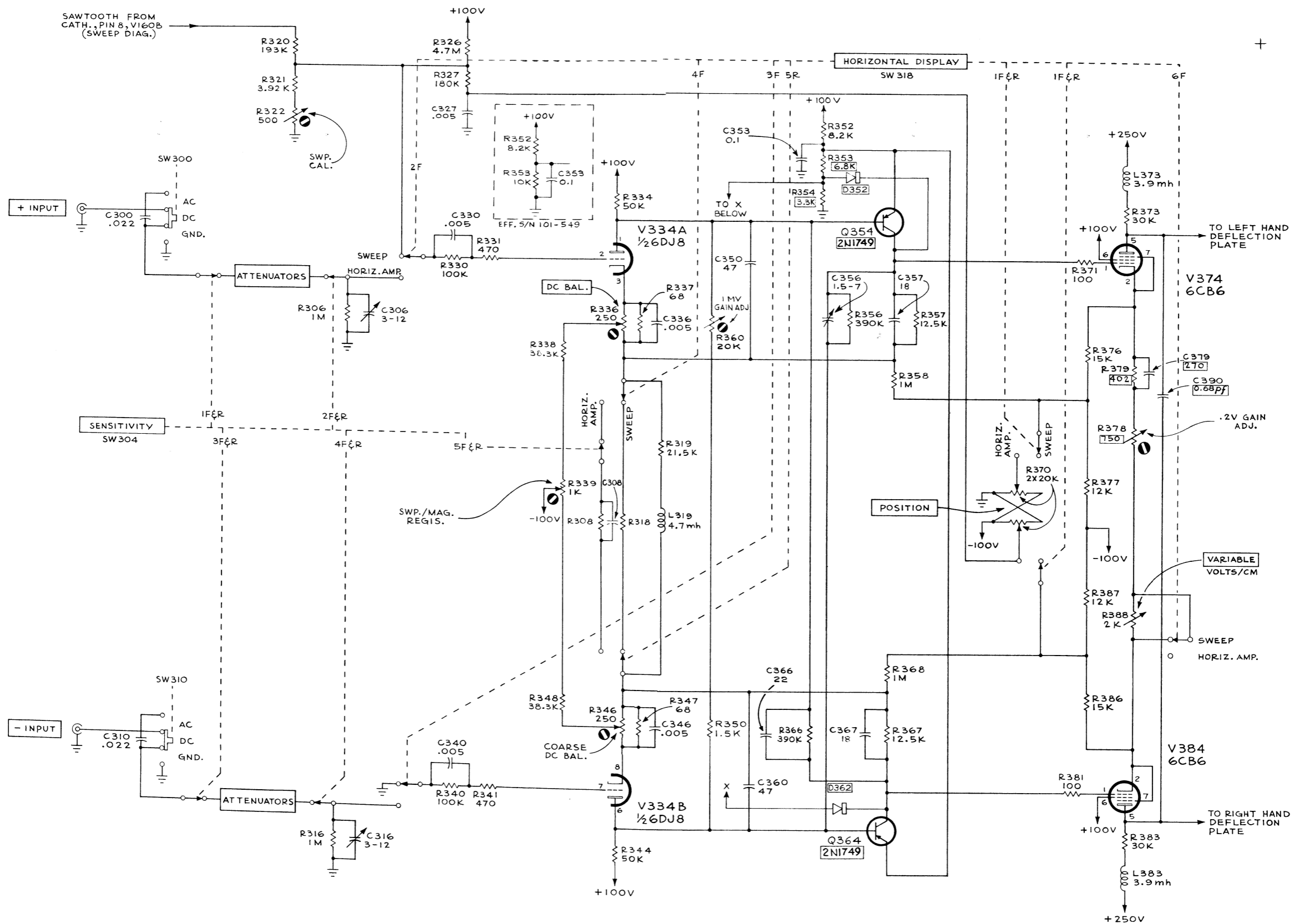

HORIZONTAL AMPLIFIER

TYPE RM503 OSCILLOSCOPE

SEE PARTS LIST FOR EARLIER VALUES AND S/N CHANGES OF PARTS MARKED WITH BLUE OUTLINE.

A₂

HORIZONTAL AMPLIFIER

EFF. S/N 101-1094

CIRCUIT NUMBERS 300 THRU 399

GAB 364

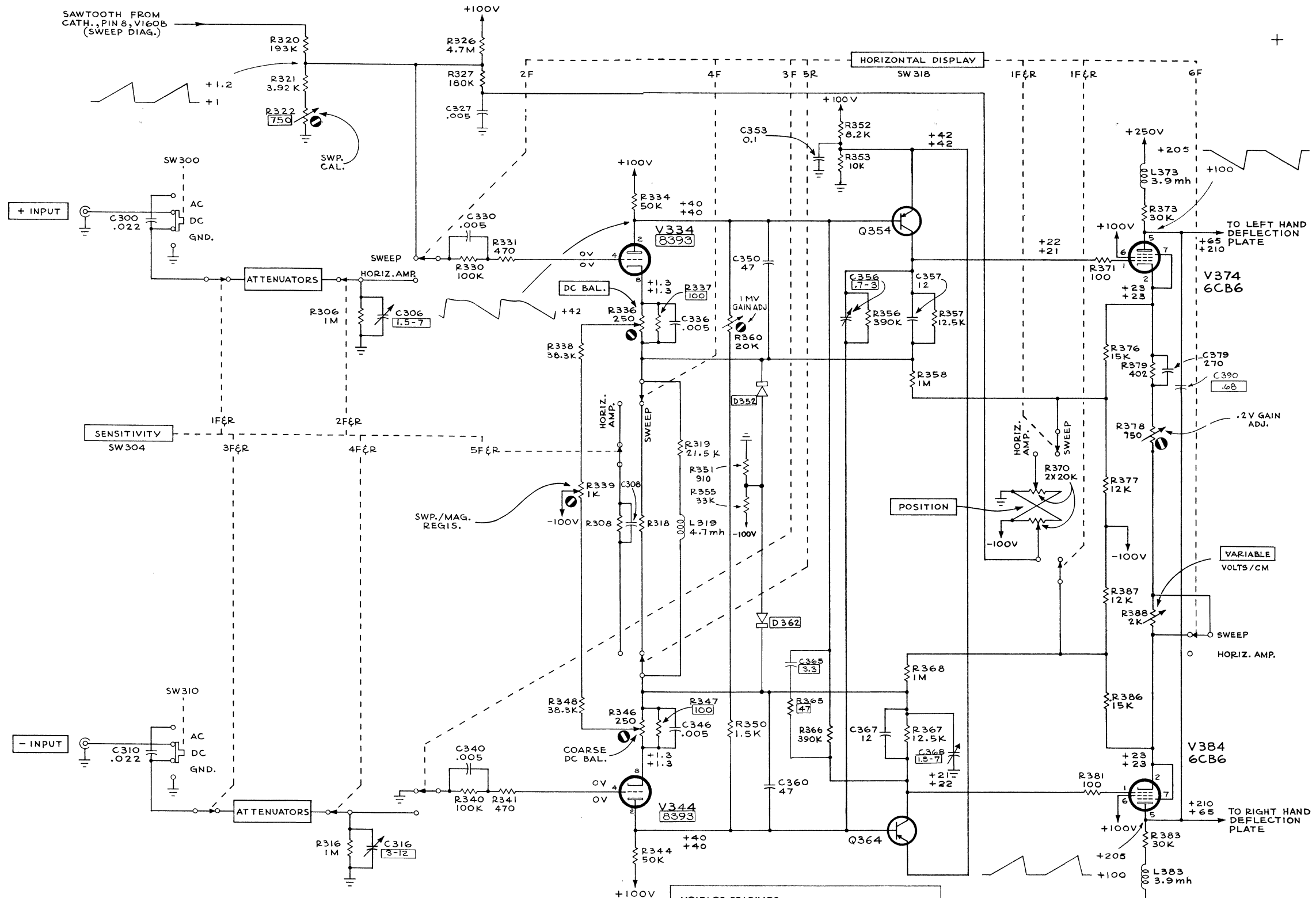

TYPE RM503 OSCILLOSCOPE

SEE PARTS LIST FOR EARLIER VALUES AND S/N CHANGES OF PARTS MARKED WITH BLUE OUTLINE.

VOLTAGE READINGS WERE OBTAINED WITH CONTROLS SET AS FOLLOWS:

BOTH HORIZONTAL INPUTS	GND
SENSITIVITY2 VOLTS/CM
HORIZONTAL POSITION	CW
FOR UPPER VOLTAGE READINGS	CCW
FOR LOWER VOLTAGE READINGS	HORIZ. AMPLIFIER (SWEEP DISABLED)
HORIZONTAL DISPLAY	

SEE ALSO IMPORTANT NOTE ON SWEEP TRIGGER DIAGRAM

SEE PARTS LIST FOR SEMICONDUCTOR TYPES

HORIZONTAL AMPLIFIER

EFF. S/N 1095 - UP

CIRCUIT NUMBERS 300 THRU 399

HORIZONTAL AMPLIFIER

GAB 666

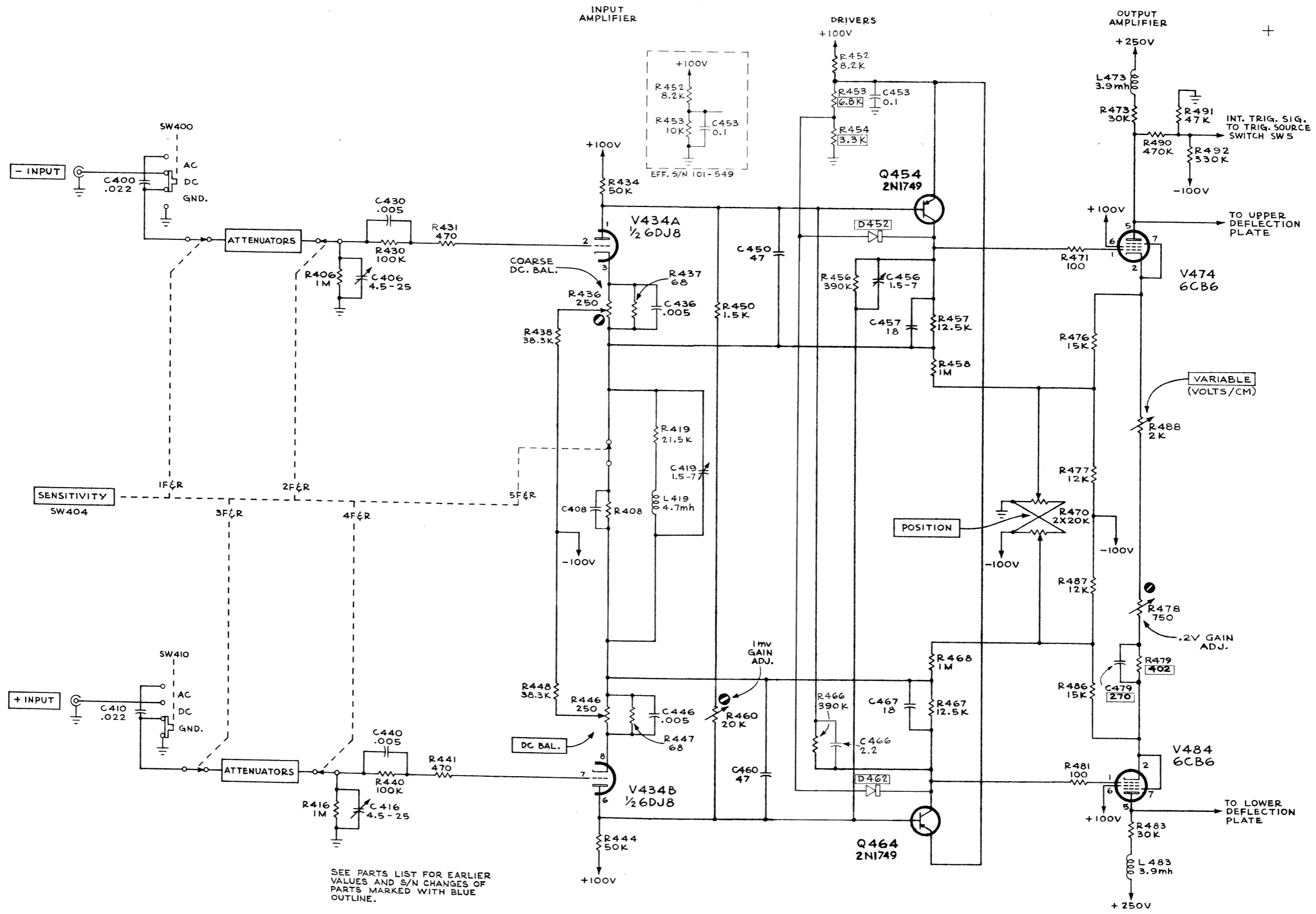

SEE PARTS LIST FOR EARLIER VALUES AND S/N CHANGES OF PARTS MARKED WITH BLUE OUTLINE.

TYPE RM503 OSCILLOSCOPE

VERTICAL AMPLIFIER

EFF. S/N 101-1094
CIRCUIT NUMBERS
400 THRU 499

VERTICAL AMPLIFIER

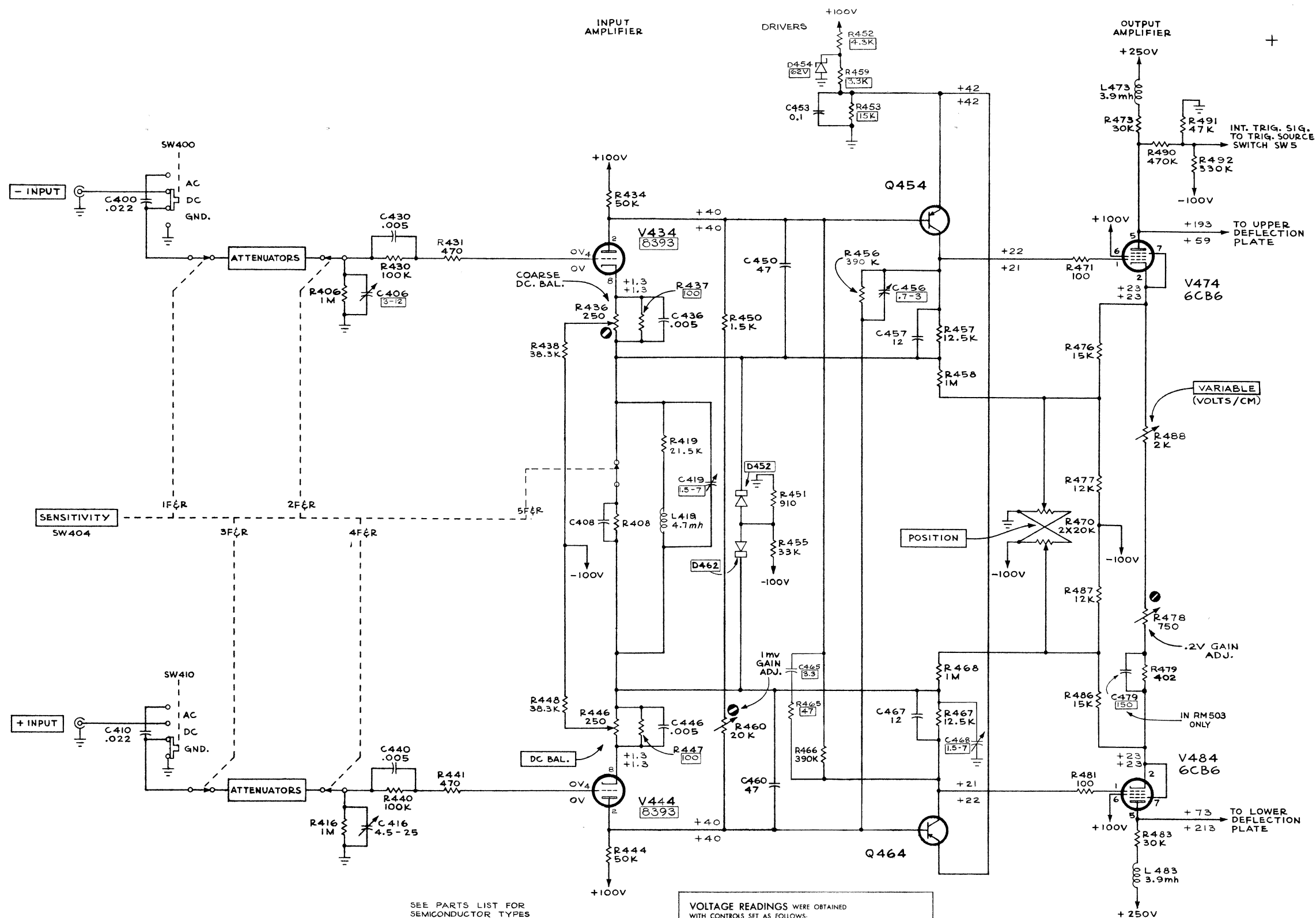

TYPE RM 503 OSCILLOSCOPE

SEE PARTS LIST FOR SEMICONDUCTOR TYPES

SEE PARTS LIST FOR EARLIER VALUES AND SERIAL NUMBER RANGES OF PARTS MARKED WITH BLUE OUTLINE.

VOLTAGE READINGS WERE OBTAINED WITH CONTROLS SET AS FOLLOWS:

BOTH INPUTS	GND
SENSITIVITY ...	2 VOLTS/CM
VERTICAL POSITION	
FOR UPPER VOLTAGE READINGS	CW
FOR LOWER VOLTAGE READINGS	CCW

SEE ALSO IMPORTANT NOTE ON SWEEP TRIGGER DIAGRAM

VERTICAL AMPLIFIER
 EFF. S/N 1095-UP
 CIRCUIT NUMBERS
 400 THRU 495

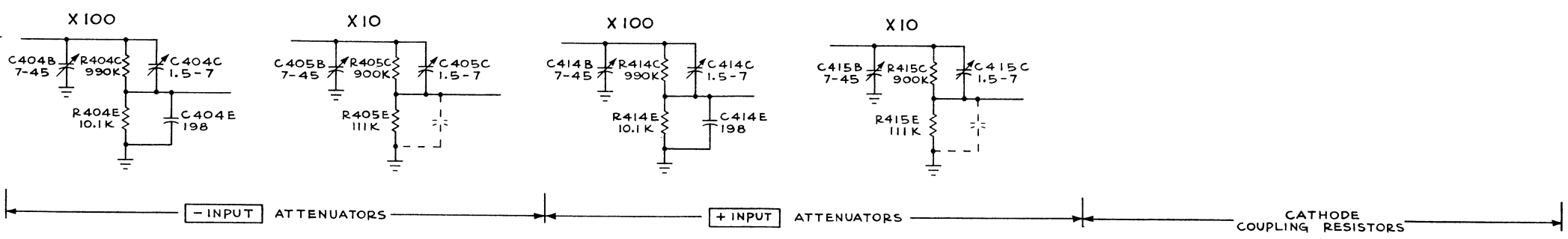
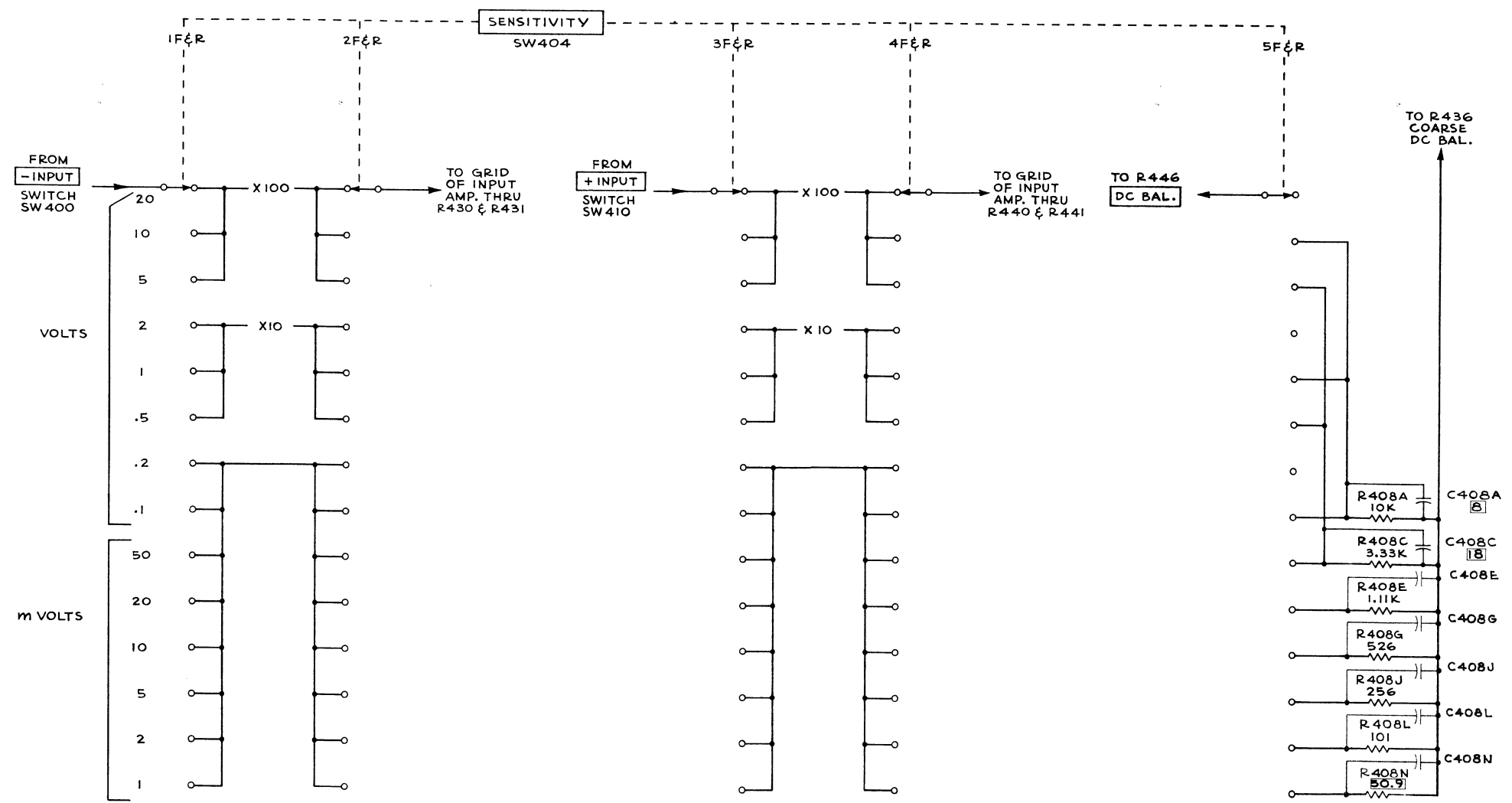

TYPE RM503 OSCILLOSCOPE

SEE PARTS LIST FOR EARLIER VALUES AND S/N CHANGES OF PARTS MARKED WITH BLUE OUTLINE.

VERTICAL AMPLIFIER ATTENUATOR SWITCH

GAB 364

VERTICAL AMP. ATTENUATOR SWITCH

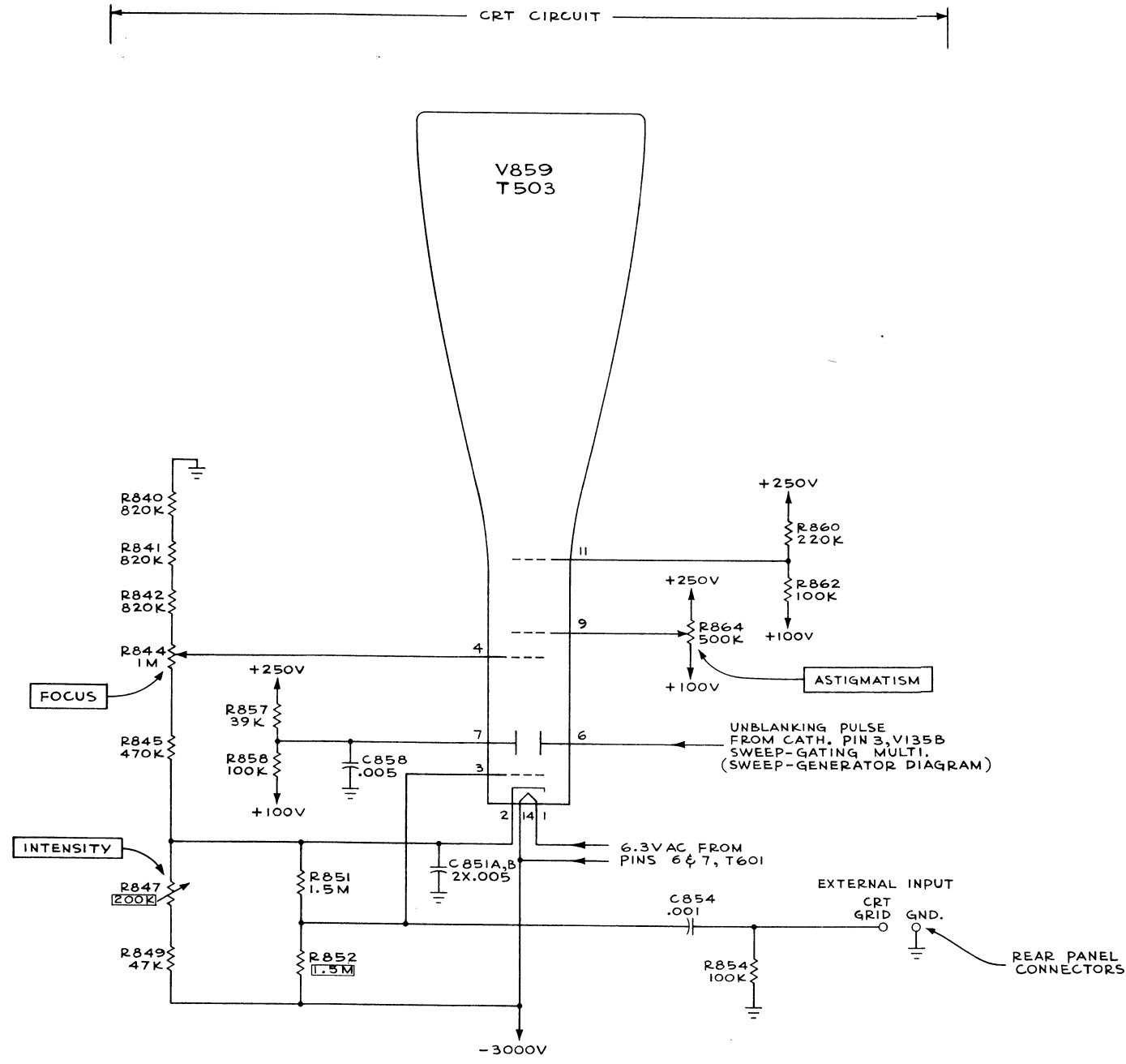

TYPE RM503 OSCILLOSCOPE

A₁

SEE PARTS LIST FOR EARLIER VALUES AND S/N CHANGES OF PARTS MARKED WITH BLUE OUTLINE.

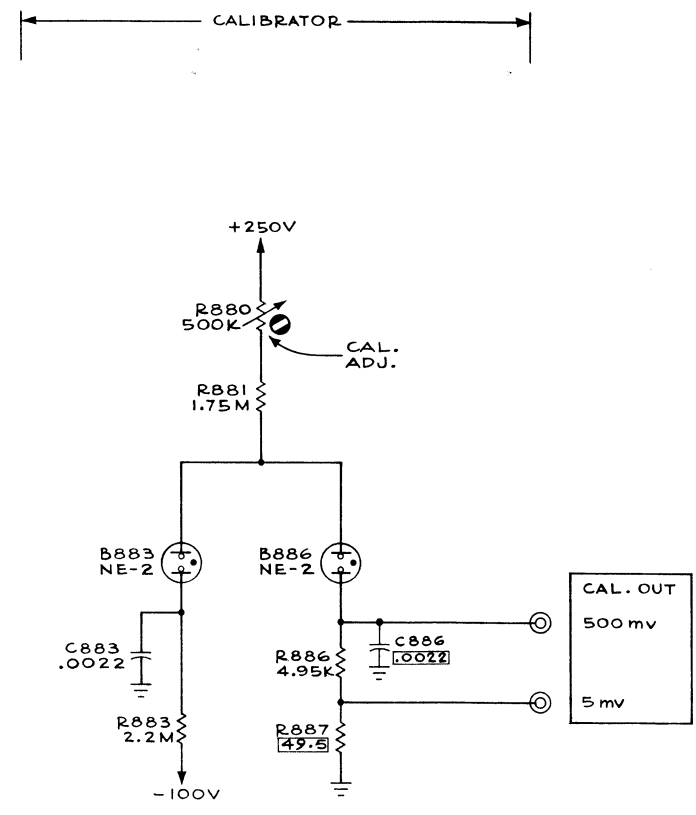

CRT CIRCUIT & CALIBRATOR

CIRCUIT NUMBERS 840 THRU 889

GAB 364

CRT CIRCUIT & CALIBRATOR

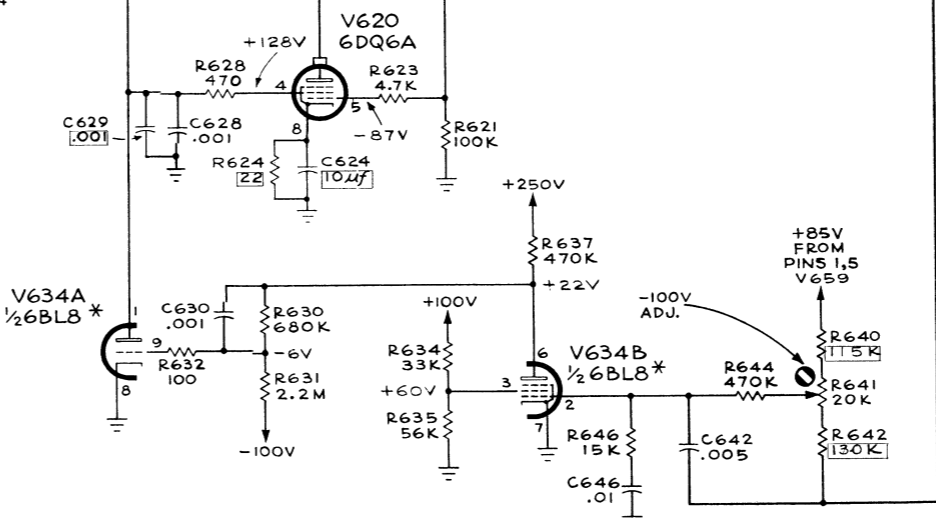
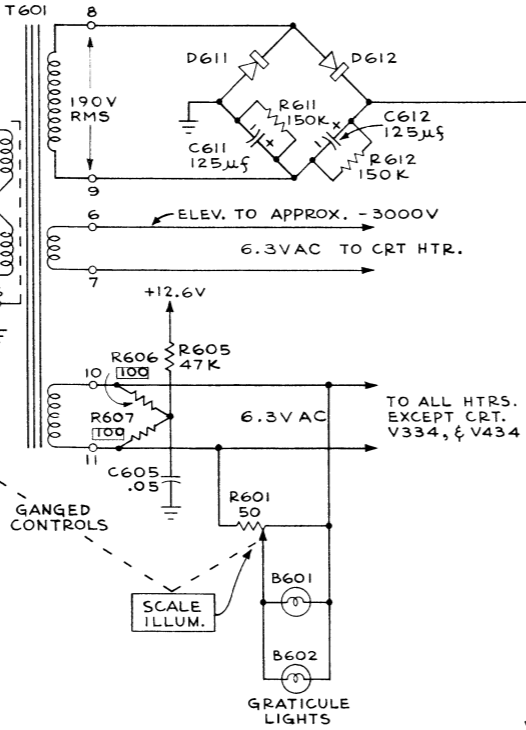
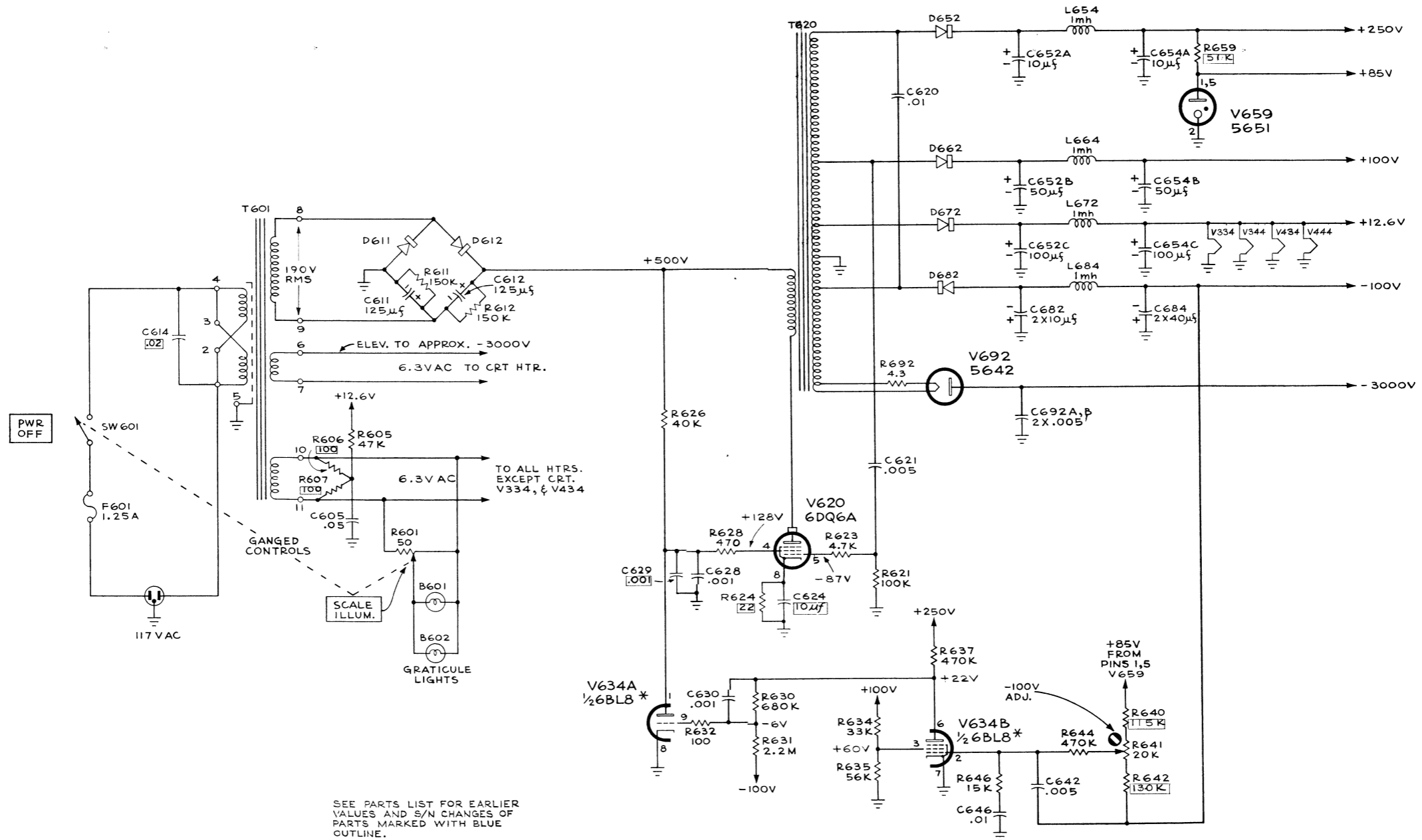

SEE PARTS LIST FOR EARLIER VALUES AND S/N CHANGES OF PARTS MARKED WITH BLUE OUTLINE.

* ECF80 MAY BE SUBSTITUTED

VOLTAGE READINGS WERE OBTAINED WITH CONTROLS SET AS FOLLOWS:
 LINE VOLTAGE 117 V 60 CPS
 TRIGGER LEVEL (SWEEP DISABLED) CCW BUT NOT SWITCHED TO AUTO
 SEE ALSO IMPORTANT NOTE ON SWEEP TRIGGER DIAGRAM
 POWER SUPPLY

POWER SUPPLY

CIRCUIT NUMBERS 600 THRU 699

TYPE RM503 OSCILLOSCOPE

G.A.B. 466

MANUAL CHANGE INFORMATION

At Tektronix, we continually strive to keep up with latest electronic developments by adding circuit and component improvements to our instruments as soon as they are developed and tested.

Sometimes, due to printing and shipping requirements, we can't get these changes immediately into printed manuals. Hence, your manual may contain new change information on following pages. If it does not, your manual is correct as printed.

TYPE 503
TYPE RM503

TENT SN 8900
TENT SN 6380

PARTS LIST CORRECTION

CHANGE TO:

R360, R460	311-0117-00	5 k	Var.	Comp.	20 %
R350, R450	302-0102-00	1 k	Fixed	Comp. 1/2 w	10 %

Text Correction

Reference: Text page 6-6 Step 16 through step 19 change
Amplifier Phasing (Type RM503, S/N 101 and up)

16. ADJUST 1 MV/CM PHASING

Set the front panel controls as follows:

HORIZONTAL DISPLAY	HORIZ. AMP ONLY
Vertical SENSITIVITY	1 MV/CM
+INPUT	DC
-INPUT	GND
Horizontal SENSITIVITY	1 MV/CM
+INPUT	GND
-INPUT	GND

With Horizontal and Vertical DC BAL. controls, center the spot on the graticule. Connect a 50-ohm 5XT attenuator to the 190B Output and add a T connector to the attenuator. Connect a 50-ohm coaxial cable from the T connector outputs to the HORIZONTAL +INPUT and the VERTICAL +INPUT. Be sure the two cables are of equal length.

Set the Type 190B for a 50 kc sine wave output and by adjusting the AMPLITUDE control and the attenuator box of the Type 190B, set the display on the Type RM503 to a 6 CM vertical trace.

Change the output frequency of the Type 190B to 450 kc. Adjust C456 so the display is exactly 4.3 CM in length.

Change the horizontal +INPUT to DC. This will make the display change to a straight line or extremely flattened ellipse at a 45° angle across the screen. Adjust the amplitude of the Type 190B to make the display 6 CM high. If the separation of the trace is greater than 1/2 minor graticule division

at the widest part of the ellipse, adjust C356 for 1/2 minor division or less of separation.

Change the output frequency of the Type 190B to 350 kc and adjust its amplitude for a 6 CM display. Trace separation should remain 1/2 minor graticule division or less.

Change the Type 190B Output frequency to 50 kc and adjust amplitude for 6 CM of display. Trace separation should be no more than 1/2 minor graticule division.

17. ADJUST .2 VOLTS/CM PHASING

Set both horizontal and vertical SENSITIVITY controls to .2 VOLTS/CM. Set vertical +INPUT to GND. Apply a 50 kc signal from the Type 190B to both horizontal and both vertical inputs. Adjust signal amplitude for 6 CM trace.

Change the Type 190B output to 450 kc. The display will contract somewhat. By changing the dress of horizontal deflection plate leads at the neck of the CRT, adjust the trace length to approximately 4.3 CM.

Set vertical +INPUT switch to DC, the horizontal +INPUT switch to GND and -INPUT switch to DC. Then adjust the Type 190B for a 6 CM display. Again, the display will be a diagonal line (45°) or flattened ellipse. Adjust C419 for minimum trace separation.

SN 5000-up Only

Set the horizontal +INPUT switch to DC and -INPUT switch to GND. Then adjust the Type 190B for a 6 CM display. Again, the display will be a diagonal line (45°) or flattened ellipse. Adjust C468 for a trace separation of 1/2 minor graticule division or less.

Set the vertical and horizontal +INPUT switches to GND and the -INPUT switches to DC. Again, the display will be a diagonal line (45°) or flattened ellipse. Adjust C368 for a trace separation of $1/2$ minor graticule division or less.

Set the vertical +INPUT switch to DC and -INPUT switch to GND. The display will be an ellipse. Adjust C419 for $1/2$ minor graticule division or less of trace separation.

Set the vertical +INPUT switch to GND and -INPUT switch to DC. Set the horizontal +INPUT switch to DC and -INPUT switch to GND. Check for the same trace separation as observed when the vertical +INPUT switch was at GND, -INPUT switch at GND and horizontal +INPUT switch was at GND, -INPUT switch at DC. If the trace separation is not the same, readjust C419 until the trace separation for the two input switch conditions is the same.

The above adjustments (C419, C468 and C368) interact and will have to be repeated several times to achieve optimum performance.

18. CHECK 1 VOLTS/CM TO .2 VOLTS/CM PHASING

Set both horizontal and vertical SENSITIVITY controls to 1 MV/CM, the +INPUT switches to DC and -INPUT switches to GND. Apply a 50 kc signal from the Type 190B to both horizontal and both vertical inputs. Adjust signal amplitude for a 6 CM display, then check the amount of trace separation. Table 1 lists the vertical and horizontal SENSITIVITY control settings, the Type 190B frequencies to be checked. It also lists the maximum

trace separation in each case. In all cases the signal amplitude is 6 CM.

TABLE 1

SENSITIVITY Vertical and Horizontal	Type 190B Frequency	Maximum Trace Separation
1 MV/CM	50 kc	1/2 minor division
1 MV/CM	350 kc	1/2 minor division
1 MV/CM	450 kc	1/2 minor division
2 MV/CM	50 kc	1/2 minor division
2 MV/CM	350 kc	1/2 minor division
2 MV/CM	450 kc	1/2 minor division
5 MV/CM	50 kc	1/2 minor division
5 MV/CM	350 kc	1/2 minor division
5 MV/CM	450 kc	1/2 minor division
10 MV/CM	50 kc	1/2 minor division
10 MV/CM	350 kc	1/2 minor division
10 MV/CM	450 kc	1/2 minor division
20 MV/CM	50 kc	1/2 minor division
20 MV/CM	350 kc	1/2 minor division
20 MV/CM	450 kc	1/2 minor division
.1 VOLTS/CM	50 kc	1/2 minor division
.1 VOLTS/CM	350 kc	1/2 minor division
.1 VOLTS/CM	450 kc	1/2 minor division
.2 VOLTS/CM	50 kc	1/2 minor division
.2 VOLTS/CM	350 kc	1/2 minor division
.2 VOLTS/CM	450 kc	1/2 minor division

Set horizontal and vertical +INPUT switches to GND and -INPUT switches to DC. Repeat the checks in Table 1.

Set the horizontal +INPUT switch to DC and -INPUT switch to GND. Repeat the checks in Table 1.

Set the horizontal +INPUT switch to GND and -INPUT switch to DC. Set the vertical +INPUT switch to DC and -INPUT switch to GND. Repeat the checks in Table 1.

19. CHECK COMMON MODE REJECTION RATIO

Set both horizontal and vertical SENSITIVITY controls to 1 VOLTS/CM. Set the horizontal +INPUT and -INPUT switches to DC, and the vertical +INPUT to DC and -INPUT to GND. Set the trigger LEVEL control to FREE RUN. Apply a 50 kc signal from the Type 190B to both horizontal and both vertical inputs. Adjust signal amplitude for a 4 CM trace.

Change the horizontal and vertical SENSITIVITY controls to .2 VOLTS/CM and the vertical -INPUT switch to DC. Using Table 2, check for not more than the listed vertical and/or horizontal deflection anywhere within the graticule area for the listed horizontal and vertical SENSITIVITY control settings. The Type 190B output frequency and amplitude remains the same for all checks in Table 2.

TABLE 2

SENSITIVITY Vertical and Horizontal	Maximum Signal Horizontal and/or Vertical
.2 VOLTS/CM	1 minor division
.1 VOLTS/CM	2 minor divisions
50 MV/CM	4 minor divisions
20 MV/CM	1 major division
10 MV/CM	2 major divisions

With a 50 kc signal from the Type 190B still connected to both horizontal and both vertical inputs, reset the SENSITIVITY controls to 1 VOLTS/CM and the vertical -INPUT switch to GND. Adjust signal amplitude for a 1 CM trace.

Change the horizontal and vertical SENSITIVITY controls to 5 MV/CM and the vertical -INPUT switch to DC. Using Table 3, check for not more than the listed vertical and/or horizontal deflection anywhere within the graticule area for the listed horizontal and vertical SENSITIVITY control settings. The Type 190B output frequency and amplitude remains the same for all checks in Table 3.

TABLE 3

SENSITIVITY Vertical and Horizontal	Maximum Signal Horizontal and/or Vertical
5 MV/CM	2 major divisions
2 MV/CM	5 major divisions
1 MV/CM	10 major divisions

Disconnect the Type 190B from the four inputs of the Type RM503 Oscilloscope.

TYPE 503
TYPE RM503

TENT SN 8750
TENT SN 6270

PARTS LIST CORRECTION

CHANGE TO:

R308N	323-0068-00	49.9 Ω	1/2 w	1 %
R408N	323-0068-00	49.9 Ω	1/2 w	1 %



TYPE 503
TYPE RM503

TENT SN 8680
TENT SN 6230

PARTS LIST CORRECTION

CHANGE TO:

R19	301-0225-00	2.2 meg	1/2 w	±5 %
R20	301-0274-00	270 k	1/2 w	±5 %